

SUBMERSIBLE MAGNET DRIVE PUMP

SUBMERSE

YD-25A6GWN1

INSTRUCTION MANUAL

VERSION: 170112

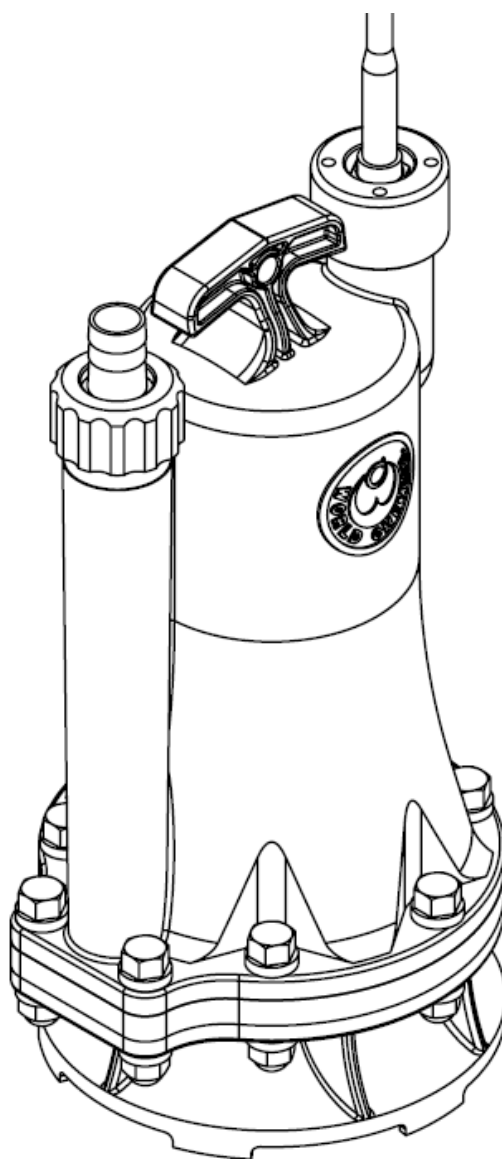

 **World Chemical Co., Ltd.**

Preface

Thank you very much for purchasing World Chemical's submersible magnet drive pump "SUBMERSE". To effectively use the pump, it is necessary to properly operate and periodically maintain the pump in accordance with the instruction manual. Use the pump after careful understanding of safety precautions in this manual. It is also recommended to store this manual where it can be easily accessed.

Meanwhile, we are not responsible for any accidents by the use of the pump which is not indicated in this manual. When it is necessary to be equipped safety measures, contact your supplier or us.

The pump and information in this manual is subject to change the specification without notice by the improvement or design changes.



Table of contents



1. Safety precaution	2
2. Model description / Performance	7
3. Outline dimension / Parts	8
4. Installation	9
5. Connection of the power and motor.....	10
6. Check	10
7. Operation.....	11
8. Disassembly / Assembly	12
9. Troubleshooting.....	13
10. Warranty / Repair.....	Error! Bookmark not defined.

1. Safety precaution

The following procedures are intended to protect you from personal injury and/or property damage.

- The following symbols classify the degree of danger and explain the damages that could occur when its contents are ignored, or the pump is used improperly.
- Safety rules to be observed are classified and explained under the following symbols. (The following are examples of picture displays)

	Non-compliance can lead to fatal or serious injury.
Warning	
	Non-compliance can lead to some injury and/or property damage.
Caution	

	This symbol cautions people to be careful.
	This symbol signifies that this action must not be taken.
	This symbol indicates that the action must be taken.

Warning

-  (1) Dangerous liquid and atmosphere

When using the pump for dangerous liquid, adhere to facility standards determined by law and check daily to prevent liquid leakage. If the pump is operated under abnormal conditions such as liquid leakage, it may lead to serious accidents such as explosion or fire and personal injury. Follow the supplier's or manufacturer's instructions for handling liquid.

Prohibit using the pump with flammable gas or liquid. Also do not place them nearby. The motor is not explosion-proof.

When handling chemical liquid, wear the protective clothes such as protect glass, gloves and rubber boots.

If suffering chemical liquid, wash it off with large amount of water immediately and submit to medical treatment as the situation demands. If getting chemical liquid into your eyes, wash them with large amount of water immediately and be evaluated by an ophthalmologist promptly.
-  (2) Prohibit to use the damaged or modified pump

If using damaged or modified pumps, it may cause personal injuries or electric shock. Never use them. It is not covered by warranty.
-  (3) Caution in carrying and lifting a pump

Use the hoist bolt when it is attached with the pump. If not, hang the pump carefully by using a belt sling while watching the weight balance. Perform the operation by qualified personnel with the slings enough strong. Do not carry the pump by hands, may cause accidents.
-  (4) Prohibit to operate a pump with the power on

Do not check or disassemble a pump or motor with the power on. It may cause personal injuries from electric shock or getting caught in the rotor. Work after taking multiple safety measures, such as the switch for main power supply, the operation switch and the hand switch for the pump are off.
-  (5) Connecting the earth wire

If using a pump without the earth wire to the motor, it may cause electric shock. Perform it by a qualified person in accordance with electric facilities technical standards and interior wiring regulations.
-  (6) Protection of the power supply cord

Stretching, pinching or otherwise damaging the power supply cord or motor lead wire may cause fire or electric shock.

 (7) Installing the Ground Fault Interrupter (GFI)

Electric shock may occur if a pump is used without attaching ground fault interrupter. Install the Ground Fault Interrupter or the Over Current Protection device to prevent electric accidents or the motor damaged.

 (8) Caution in removing a pump

Before removing a pump from pipes, close the valves and check no liquid leakage. If contacting chemical liquid directly, it may be harmful. Wear protective gears when working.

 (9) Maintenance of equipment

When maintaining, checking or repairing, turn off the wiring circuit breaker of the primary side and place a sign “Men working” not to turn on the switch by mistake. Especially, when multiple people work together, call out each other not to power on by mistake.

Do not touch the electric equipment, wiring and switch by wet hands to prevent electric shock. It causes personal injuries, the facility damage or trouble.



Caution



(1) Unspecified use

Do not use a pump for purposes other than the specification or specified on the nameplate. Specially, check the motor specification (phase, voltage and frequency) and connect the motor. Unspecified use causes personal injuries, the pump damage or peripheral equipment damage.



(2) User restrictions

Carry, install, wire, operate and maintain the pump by experts who have full knowledge of the handling the pump.



(3) Caution in opening the package

Before opening the package, check the upside down. When opening a wooden crate or box, be careful of injury from nails and silvers.



(4) Repair and returning of a pump

For repair of a damaged pump, contact your supplier or us. When returning the pump by courier, wash the interior and exterior of the pump thoroughly and check no chemical liquid on. Then, pack the pump with a plastic bag.



(5) Resin parts

The pump is made of resin. If it is subject to impact strongly, it may cause personal injuries. Do not hit objects and climb on the pump.

Also, place the piping support not to apply the pipe load to the pump directly.

The pump is constructed by general-purpose plastic and the pressure capacity is depending on the temperature unlike the metal pump. Therefore, check the acceptable pressure carefully when using the pump for high temperature liquid.

Pump component parts: Carbon fiber reinforced polypropylene / Alumina ceramics / CFR PTFE

O-rings: FPM (Fluorine-rubber)

Use the pump for liquid which is acceptable for the above material.

The chemical resistance is greatly affected by the used liquid's kind, concentration, temperature, interaction of several liquid, material stress, wetted time or other conditions by itself or with others.

For this reason, we are not responsible for the chemical resistance and recommend the chemical resistance is tested as ahead of time as possible before using.

It sure is the aged deterioration happens for the installed environment. For the pump's long life, it is recommended to do daily inspection and strive for the early reaction including parts replacement.



(6) Start-up a pump

Do not run dry definitely.

The impeller bearing and shaft are burned, and the molded thermoplastic resin parts are melted. It may cause liquid leakage or the pump damage.



(7) Operation of a pump

Do not start and stop a pump at short intervals such as the intermittent operation. It is designed for the continuous operation.

The intermittent operation causes liquid leakage from the parts' connection or fatigue breakdown by the fluctuation load inside of the pump. Furthermore, do not open and close the discharge valve at intervals of a few seconds during the continuous operation.



(8) Disposal of a pump

When disposing a used pump, wash adhered liquid off and discard it as industrial waste according to the law.



(9) Leak protection

Make sure to take appropriate preventative measures to safeguard against liquid leakage by breakdown of the pump or piping.



(10) Liquid to be used

When using a pump for hazardous liquid such as cyanogen, make sure to take appropriate preventative measures to safeguard against liquid outflow.

Place equipment for unexpected accidents.

Equip the liquid level control device which makes the motor stop at the same time as the alarm rang, when decreasing the liquid level. Additionally, install the device which opens the valves fully.

The impeller is contained magnets. If using the pump for liquid with iron or slurry, the parts may become worn or damaged.

The limit of liquid: Temperature: 40 degrees or less

 Viscosity: 30MPa·s or less (at 20 degrees, S.G.1.0)



(11) Disassemble a pump

Do not disassemble a motor including the cable.

The use after the pump is assembled or disassembled by customer self is not covered by warranty. It is recommended not to do as much as possible.

When the motor is overhauled, contact your supplier or us.

2. Model description

YD - 25 A6 GWN1 – CP – R D 5 2

(1) (2) (3) (4) (5) (6) (7) (8)

- | | |
|--------------------------------------|--|
| (1) Discharge outlet | 25: 25A |
| (2) Motor output / voltage | A6: Single phase / 100V / 260W |
| (3) Pump model | GWN1: Submersible pump |
| (4) Main material | CP: Carbon fiber reinforced polypropylene (CFR PP) |
| (5) Bearing material | R: Carbon fiber reinforced PTFE (CFR PTFE) |
| (6) O-ring material | D: FPM (Fluorine-rubber) |
| (7) Frequency | 5: 50Hz 6: 60Hz |
| (8) Limit of liquid specific gravity | 2: S.G.1.2 |

[Standard performance]

Model	Frequency Hz	S.G.	Standard performance		Motor			Weight
			T.H.D.	Capacity	Output	Voltage/PH	Ins.	
YD-25A6GWN1-CP-RD52	50	1.2	6m/19.7ft	60L/min (16gpm)	0.26kW	100V Single	E	14kg (30lbs)
YD-25A6GWN1-CP-RD62	60		6.5m/21ft					

*Other Voltage is available such as 115V, 220V, 230V.

[Caution]

- The above standard performance is under the clear water (S.G.1.0) and 20 degrees.
- The minimum flow rate during operation: 5L/min
- The dimension of the hose: Inner diameter 25mm x Outer diameter 33mm
- The minimum liquid level at continuous operation: 400mm
- The minimum operational liquid level : 100mm

3. Outline dimension / Parts

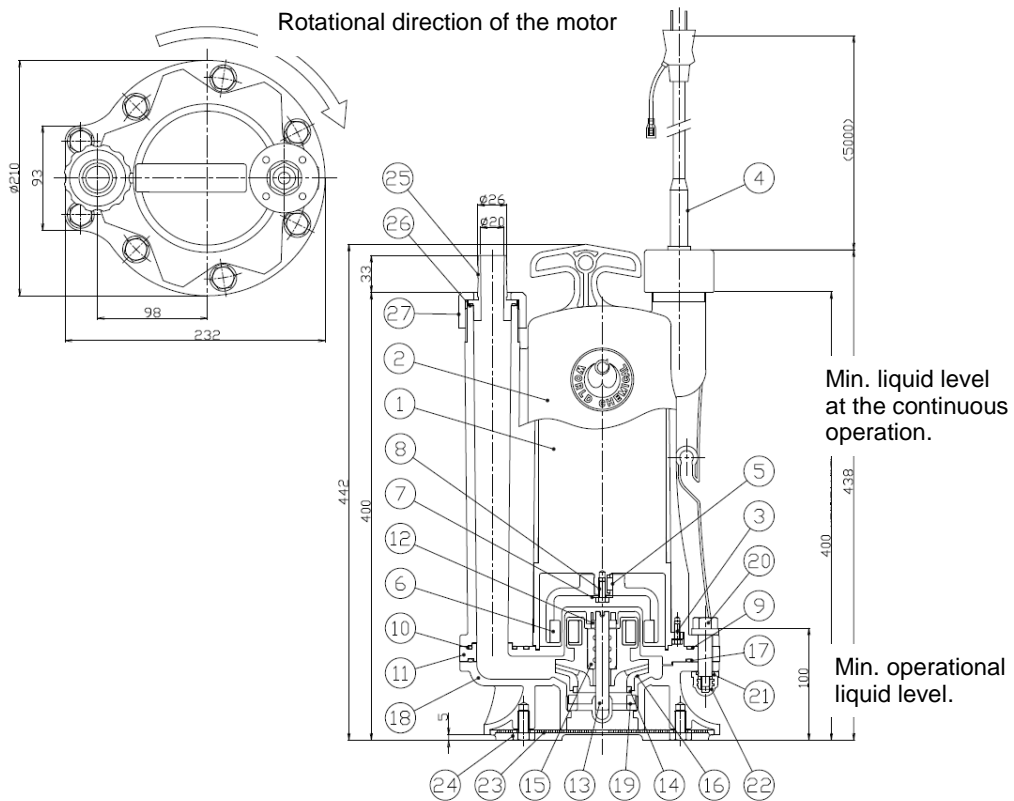

No.	Part's name	Qty	Material	Remarks
1	Motor	1	FC	
2	Motor cover	1	CFR PP	
3	Hex. bolt	4	SUS304	M5 x 15
4	Cabtyre cable	1	CR	2PNCT
5	Key	1	S45C	5 x 5 x 10
6	Outer magnet	1	Ferrite	
7	Flat washer	1	SUS304	
8	Hex. bolt	1	SUS304	M6 x 15
9	O-ring for rear casing	1	FPM	
10	O-ring for discharge outlet	1	FPM	P38
11	Rear casing	1	CFR PP	
12	Rear thrust ring	1	Alumina ceramic	
13	Shaft	1	Alumina ceramic	
14	Mouth ring	1	CFR PTFE	
15	Bearing	1	CFR PTFE	
16	Impeller	1	CFR PP	
17	O-ring for casing	1	FPM	
18	Casing	1	CFR PP	
19	Liner ring	1	Alumina ceramic	
20	Bet bolt 37	8	CFR PP	
21	O-ring for set bolt	8	FPM	P12
22	Set bolt nut	8	CFR PP	
23	Strainer	1	CFR PP	
24	Hex. bolt	4	PVC	M10 x 20
25	Hose joint	1	CFR PP	
26	O-ring for hose joint	1	FPM	P34
27	Hose joint nut	1	CFR PP	

4. Installation

Warning

Install Ground Fault Interrupter to prevent the electrical shock!

Connect an earth wire!

- When installing a pump, use a rope to move it up and down.
Do not use the power supply code to move the pump. It may cause electrical leakage.
- Install the pump at the site without slurry. If the suction inlet is clogged by slurry, it causes the pump damage.
- Check the liquid level is 100mm and more when starting the pump. If not, it may cause dry running and the pump damaged.

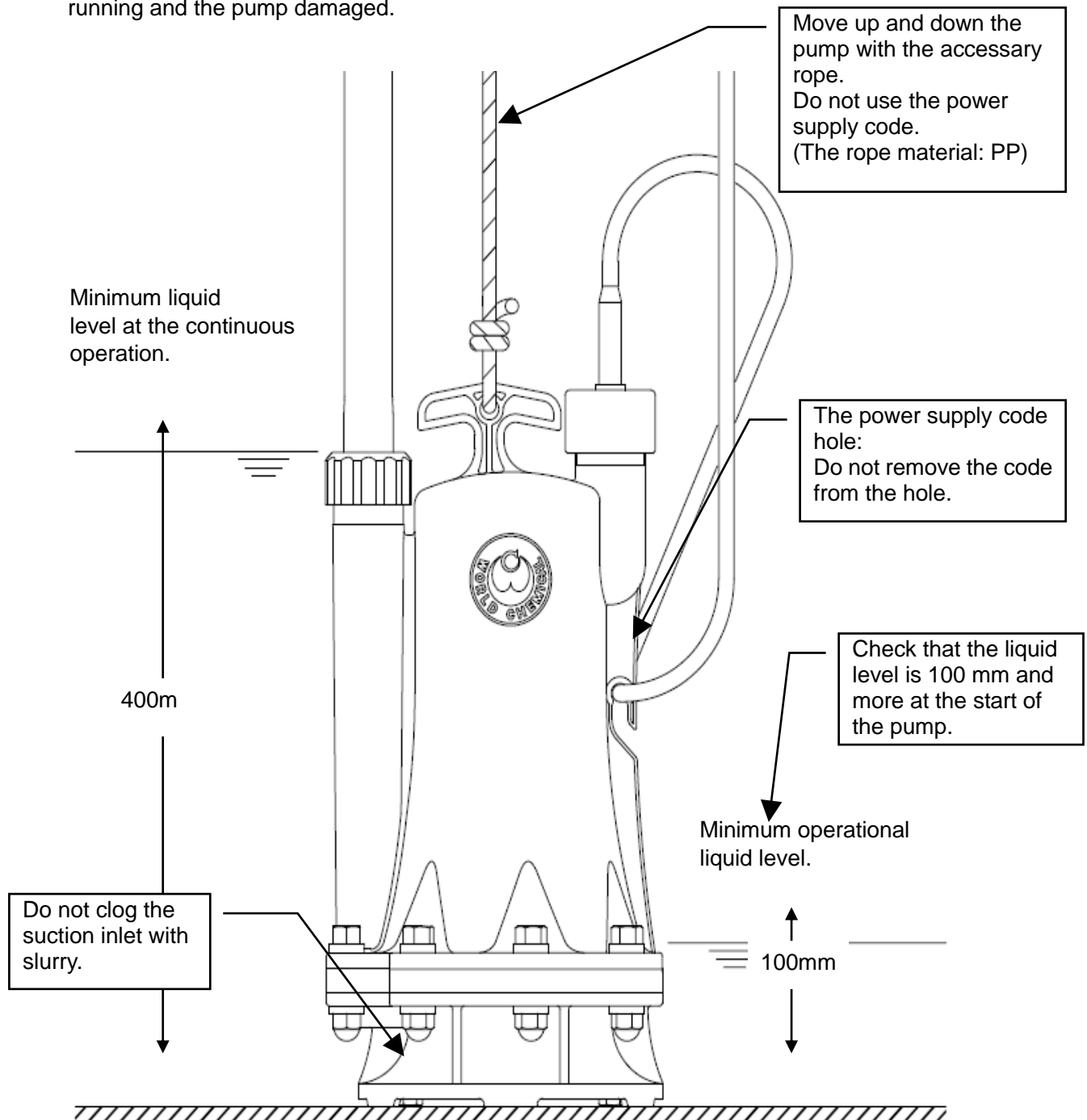

5. Connection of the power and motor

Warning

- **Install Ground Fault Interrupter to prevent electrical shock!**
- When maintaining, checking or repairing, turn off the wiring circuit breaker of the primary side and place a sign “Men working” not to turn on the switch by mistake. Especially, when multiple people work together, call out each other not to power on by mistake.
- **Make sure to connect the earth wire.
Use the plug tab when connecting it.**
- When installing the sensitive current variable type earth leakage breaker, follow the directions given by the licensed electrical engineer.
The up and down of the sensed current and the prevention of electrical shock/insulated resistance are conflicting.
- Do not touch the electrical equipment, wire and switch by wet hands to prevent the electrical shock.
- Check periodically whether the motor wiring terminal in the power board is burn or discolored. If the terminal is loosened, it may cause the burn out for heat or fire. Work it by the licensed electrical engineer.

6. Check

 **Warning**
Before operation, make sure to check the pump.

Content		Repetition	
		Daily	Once a month
1. Before Operation	1-1 Liquid leakage from connections	◎	
	1-2 Open/close of the handle of the drain valve	◎	
	1-3 Deformation of the pipe by liquid temperature	◎	
	1-4 Loosen bolts at connections		
	1-5 Liquid leakage from the outside of pipes	◎	◎
	1-6 Clean	◎	
2. During Operation	2-1 Liquid leakage from connections	◎	
	2-2 Deformation of the pump	◎	
	2-3 Motor noise	◎	
		◎	
3. At the end	3-1 Clean	◎	

7. Operation



Warning

- After operation, check no liquid leakage, the noise of the pump and motor and the state of drain. If the abnormal state is found, stop the pump immediately and take measures.
- When blackout or the electric power failure, turn off the switch and start each pump one by one after recovery.

■ The minimum liquid level during operation

Keep the liquid level which the whole of the pump is submerged in.

(The minimum liquid level at continuous operation: 400mm and more from the mounting surface of the pump)

If the pump is operated at continuous operation below the minimum liquid level, it is 5 minutes or less. Do not operate the pump at short intervals.

※ According to the operation condition, the built-in thermal protector is activated and the pump stops. At such times, pause the operation and check whether there is abnormality. After securing the proper liquid level, start the pump.

The operational minimum liquid level at the start of the pump is 100mm and more.

※ Even if the liquid level is over the operational liquid level, air may enter the pump and the operation may be failure depending on the condition of the liquid surface.

※ When operating the pump in the air, the rotation parts inside of the pump may be damaged.

■ Measures against air lock

If there are areas where the liquid stands in the drain pipe when stopping the pump, pumping failure may occur at the re-start of the operation by air lock. The same phenomenon easily happens after deadhead running. In this case, install the air release valve on the discharge pipe, or make sure to release the air and pour priming liquid in the pump casing before the operation.

When placing check valves on the suction pipe, install exhaust bypass pipes underneath. (If there is not air release pipe, it may cause air lock.)

8. Disassembly / Assembly

[Disassembly]

- [A] Remove eight bolts (20) which fix the motor cover (2) and the casing (18).
- [B] The parts below the rear casing (11) is separated from the motor cover (2).
- [C] Heave the rear casing (11) and remove the impeller (16).
 - ※ At this time, the motor becomes exposed and be careful not to wet the metal part by chemical liquid.
 - ※ Do not be adhered the dirt or foreign objects to the O-rings or seal parts.

[Assembly]

- [A] Check the motor dry, clean O-rings off and set them as the same way as disassembly.
- [B] Tighten the set bolts (20) alternately and diagonally with the torque $7.5\text{N} \cdot \text{m}$.

■ Never disassemble the motor.

In our factory, the pressure resistant / leaked tests are conducted to check that no liquid enters in.

The use after customer disassembles and assembles the motor is not covered by warranty.

When overhauling a pump, contact your supplier or us.

■ Exploded view

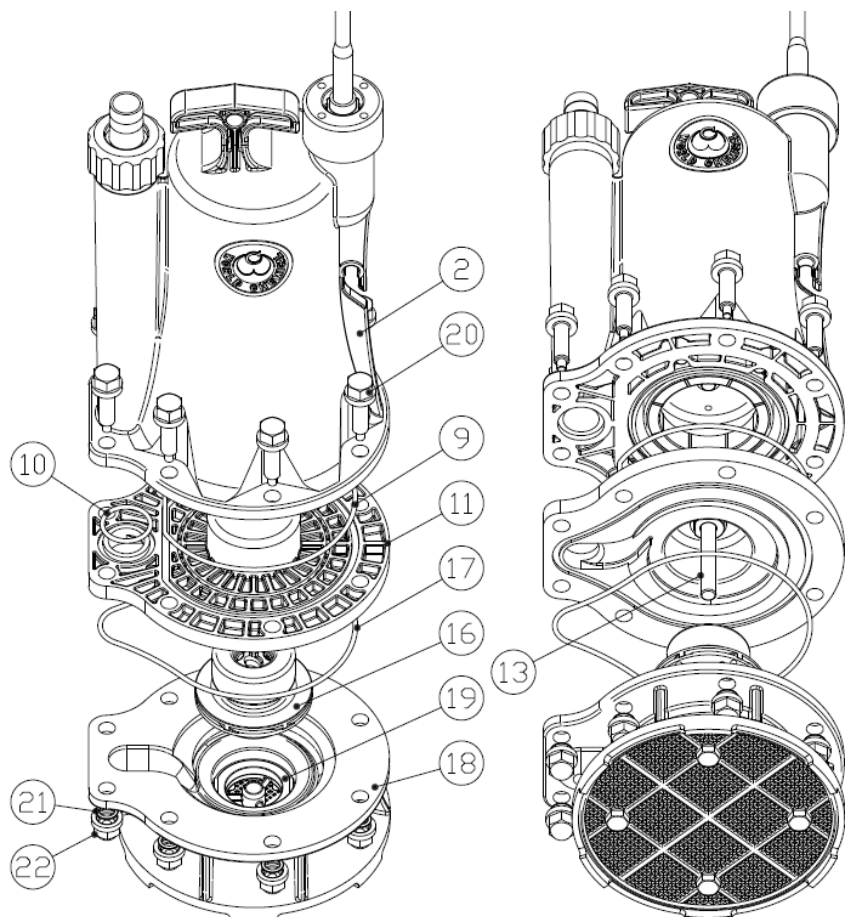

9. Troubleshooting

1. Unable to pump up and insufficient pumping

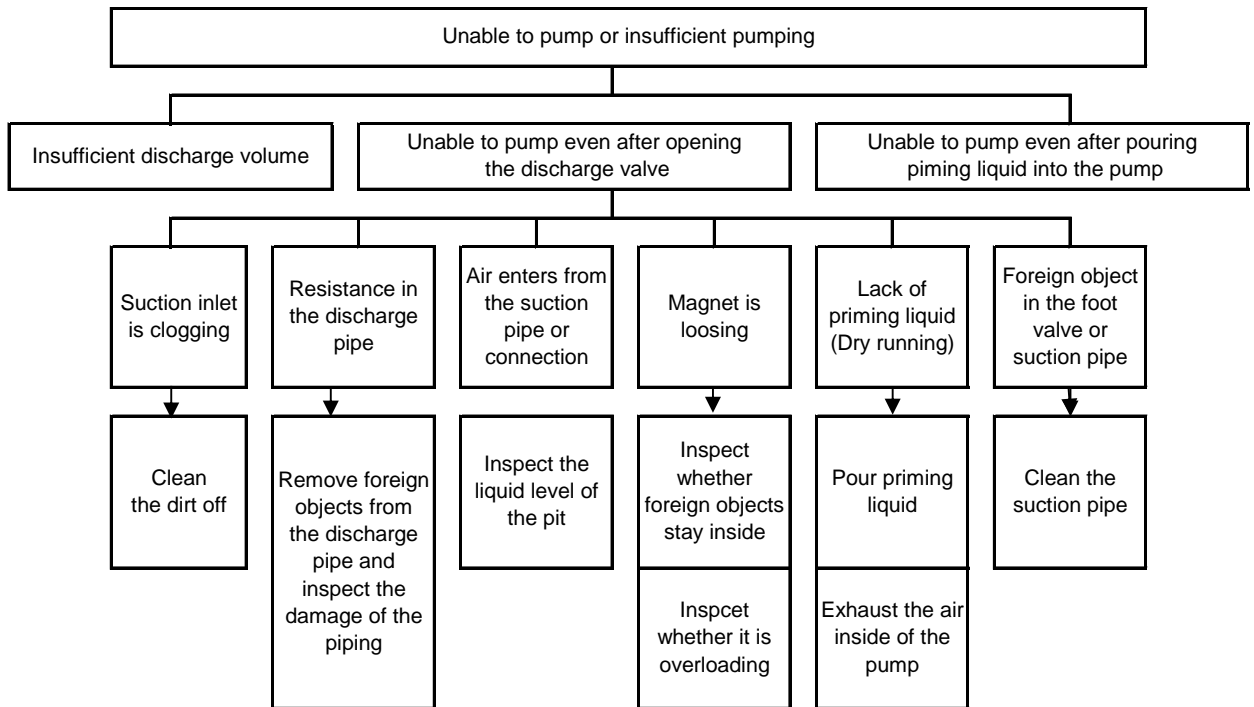

2. Pump vibrates

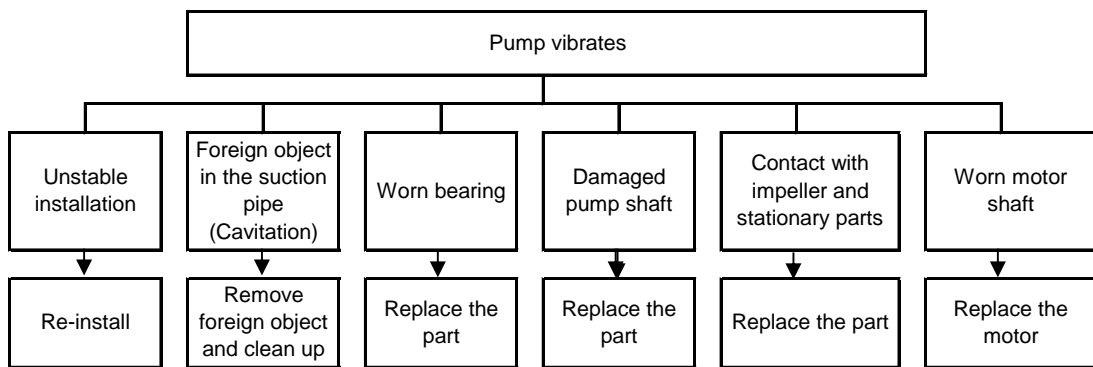

**10. WORLD CHEMICAL USA (“WCUSA”)
STANDARD ONE-YEAR LIMITED WARRANTY
FOR SALES MADE ONLY IN THE UNITED STATES, CANADA**

**This limited warranty completely replaces the warranty issued by World Chemical Co., Ltd.
relating to the below described Pumps.**

WCUSA warrants its Magnetic Drive Pumps, Self-Priming Pumps, Oil Skimmer Systems, Vertical Pumps and Submersible Pumps (“Pumps”) against defects in materials and workmanship for one year from the date of WCUSA’s invoice to you for the affected Pump. This warranty requires you to return the Pump to WCUSA.

If there is a manufacturing defect, WCUSA will replace or repair the Pump with new or rebuilt parts at no charge to you. Please return the Pump to: World Chemical USA, 30 Hughes, Ste 203, Irvine, CA 92618.

When returning the Pump, include your name, address, daytime telephone number, and a description of the problem. No warranty work can be performed without this information.

Properly pack the Pump (preferably in the original carton) to prevent damage to the Pump in transit.

The repaired or replaced Pump will be warranted for a period equal to the remainder of the original one-year warranty.

All replaced Pumps, parts and components, shall become the property of WCUSA

This Limited Warranty does not cover: (a) defects or damage resulting from accident, misuse, abnormal use, abnormal conditions, improper storage, exposure to dirt, neglect, or unusual physical, electrical or electromechanical stress; (b) scratches, dents and cosmetic damage, unless caused by WCUSA; (c) Pump that has the serial number removed, defaced, damaged, altered or made illegible; (d) ordinary wear and tear; (e) defects or damage resulting from the use of Pump in conjunction or connection with other equipment not furnished or approved by WCUSA; (f) defects or damage resulting from improper testing, operation, maintenance, installation, service, caused by the use of unauthorized parts of service; (g) defects or damage resulting from external causes such as collision with an object, fire, flooding, dirt, windstorm, lightning, earthquake, exposure to weather conditions, or improper use of any electrical source; (h) irregularities or breakdowns due to chemical or hydrodynamic corrosion by liquid. We do not warrant the chemical resistance of the Pump to any chemical or to corrosion.

You will be responsible for paying for your own shipping costs for delivering the Pump to us. If we determine the Pump is covered by this warranty, we will return the new or repaired Pump to

you at our expense. If we determine that the Pump is not covered by this warranty, we will return it at your expense.

WCUSA does not warrant accessory components, including, but not limited to, Impeller (including mouth ring and bushing), Rear Casing set (include shaft), O-Ring for Casing and other consumable parts.

REPLACEMENT OR REFUND OF THIS PUMP AS PROVIDED UNDER THIS LIMITED WARRANTY IS BE YOUR EXCLUSIVE REMEDY.

WE ARE NOT RESPONSIBLE OR LIABLE FOR ANY LOSS, INCONVENIENCE OR DAMAGE, WHETHER SPECIAL, DIRECT, INCIDENTAL, CONSEQUENTIAL, OR OTHERWISE, AND WHETHER KNOWN OR SHOULD HAVE BEEN KNOWN TO US, INCLUDING LOST PROFITS, GOODWILL, DAMAGE TO OR REPLACEMENT OF OTHER PUMPS AND PROPERTY AND PERSONAL INJURY RESULTING FROM ANY BREACH OF WARRANTY, THE INABILITY TO USE THE PUMP OR UNDER ANY LEGAL THEORY IN CONTRACT OR TORT. THESE WARRANTIES AND REMEDIES ARE YOUR SOLE AND EXCLUSIVE WARRANTIES AND REMEDIES IN CONNECTION WITH THE SALE AND USE OF THE PUMP. NO OTHER WARRANTIES, ORAL OR WRITTEN, EXPRESS OR IMPLIED, ARE GIVEN. OUR LIABILITY IS LIMITED TO THE ACTUAL PURCHASE PRICE YOU PAID TO THE RETAIL SELLER OF THE DEFECTIVE PUMP. EXCEPT TO THE EXTENT PROHIBITED BY LAW, ANY IMPLIED WARRANTIES OR CONDITIONS OF MERCHANTABILITY AND FITNESS FOR A PARTICULAR PURPOSE ARE LIMITED IN DURATION TO THE DURATION OF THIS LIMITED WARRANTY.

Some states do not allow the exclusion or limitation of implied warranties or liability for incidental or consequential damages, or do not allow a limitation on how long an implied warranty lasts, so the above limitations or exclusions may not apply to you. You are advised to contact applicable state laws for a full determination of your rights. This warranty gives you specific legal rights, and you may have other rights which vary from state to state.

No dealer, agent or employee is authorized to make any modification, extension, change or amendment to this warranty. This warranty may not be assigned without the prior expenses written approval of WCUSA.



WORLD CHEMICAL CO., LTD.

Head Office / Overseas department

3F., ANTEX24, 1-1-14, Taito. Taito-ku, Tokyo, 110-0016 Japan

TEL: 03-5818-5130 FAX: 03-5818-5131 (Head office)

TEL : 03-5818-5131 FAX : 03-5818-5131 (Overseas department)

Osaka Office

7F., KUJO Bldg., 1-27-6, Kujo, Nishi-ku, Osaka-shi, Osaka, 550-0027 Japan

TEL: 06-6584-3185 FAX: 06-6584-3160

Nagoya Office

1F., EIKEI Bldg., 1-307, Yashirogaoka, Meito-ku, Nagoya-shi, Aichi, 465-0051 Japan

TEL 052-701-1227 FAX 052-701-1250

Tsukuba Factory

6127-5, Onogo-machi, Joso-shi, Ibaraki, 300-2521 Japan

TEL 0297-24-1071 FAX 0297-24-1075

WORCHEMI TAIWAN CO., LTD. / Taichung, Taiwan

No.915, Zhongshan Rd., Shengang Dist., Taichung City 42955, TAIWAN

TEL 886-4-2562-8358 FAX 886-4-2562-8351

WORLD CHEMICAL USA, INC. / California, U.S.A.

30 Hughes, Suite 203, Irvine, CA 92618, U.S.A.

TEL 1-949-462-0900 FAX 1-949-462-0999

SUZHOU WORLD TECHNOLOGY CO., LTD. / Jiangsu, China

402, Fu Yuan Road, Xiang Cheng Economic District, Suzhou, Jiangsu Province, China

TEL 86-0512-6579-8212 FAX 86-0512-6579-8215