

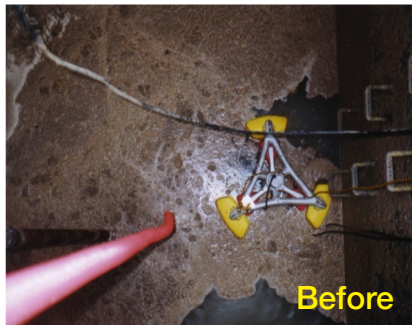

Efficient, Lightweight and Durable Oil Skimmers. The most-ideal solution for floating oil.



Before



After

Just 30min.

- No Manual labor needed
- Vacuums surface only
- Skimmer comes with pump
- Highly corrosion and heat resistant

For oil, food, ponds, paint sludge, sumps, waste water treatment and more!

Applications

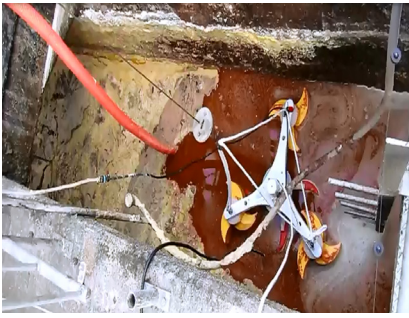

Food factory



Automobile factory



Pond



Testimonials:

Food Industry

We were using (manpower manual labor) to remove the oils that solidified. After installing the YD-GYP the efficiency has increased.

Aluminum parts manufacture

Exchanged to this from using tube skimmer. This only removes the unwanted sludge from surface saves water.

NO.	PARTS NAME	QTY	MATERIAL	NOTE
1	Submersible Pump	1	Resin with Glass Fiber/SUS	
2	Main Float	3	PE	
3	Gate Float	3	PE	
4	Float Frame	1	AL/SUS	
5	Casing	1	AL	
6	Cable Protection Base	1	SS	
7	Gate Ring	1	AL/SUS Others	
8	Hose	1	PP	φ1.0"-2.0"
9	Balance Weight	1	SS	

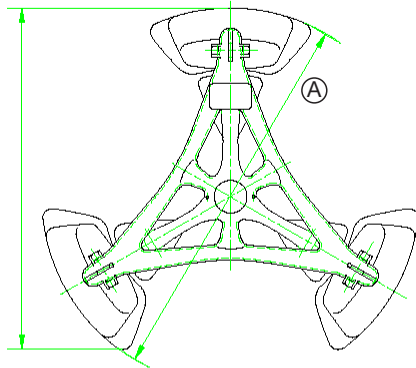

Unit: inch (mm)

MODEL	A	B	C
YD-600GYP	22.0 (560)	22.8 (580)	17.3 (439)
YD-800GYP	31.5 (800)	27.2 (690)	18.7 (476)
YD-1000GYP	39.4 (1000)	25.5 (647)	17.8 (452)
YD-1200GYP	47.2 (1200)	26.8 (680)	19.7 (500)

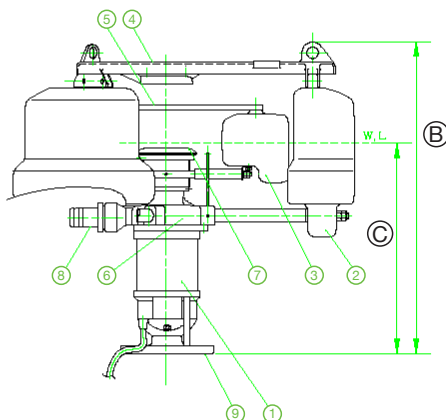

MODEL	DISCHARGE DIAMETER [in. (mm)]	TDH [ft. (m)]	CAPACITY [gpm (lpm)]	WEIGHT [lbs. (kg)]
YD-600GYP	1.0 (25)	13 (4)	4.0 (15)	28 (13)
YD-800GYP	1.5 (40)	13 (4)	10.6 (40)	48 (22)
YD1000GYP	1.5 (40)	23 (7)	13.2 (50)	53 (23)
YD-1200GYP	2.0 (50)	23 (7)	26.4 (100)	62 (28)