

**NEW**

Small magnet drive pump

**Chemi-Free**

Instruction manual

YD-16X8GS(F)1/16Y6GSH1

YD-20Y6GS(F)1/20Y6GSH(F)1

Version: 170626

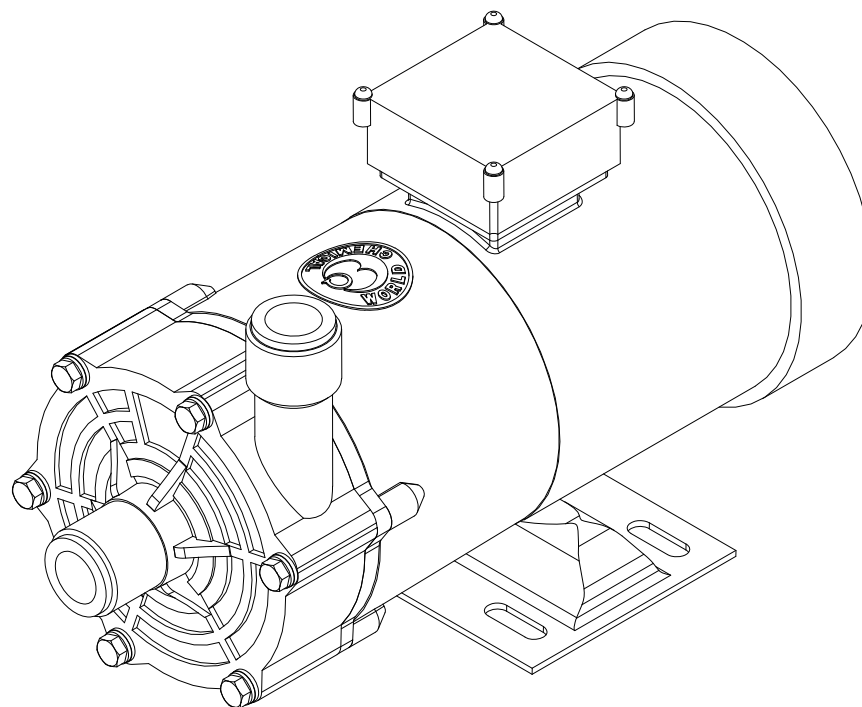

 **World Chemical CO., LTD.**

Thank you for purchasing our small magnet drive pump YD-16-20GS. This instruction manual explains safety precautions, general description, installation, operating procedures and maintenance. Please read this instruction manual thoroughly. An adequate understanding of each section is required to maximize the pump's performance and to assure safety and long-term efficiency.

## Table of Contents

Safety precautions .....	P2
General description	
1. Unpacking check .....	P4
2. Operation principle .....	P4
3. Model description .....	P5
4. Specifications .....	P5
5. Performance curve .....	P6
6. Parts name / Structure .....	P10
7. Outline dimension .....	P12
Installation	
1. Before operation .....	P14
2. Installation / piping / wiring .....	P15
Operation	
1. Operation procedure .....	P19
Maintenance	
1. Troubleshooting .....	P22
2. Maintenance / Check .....	P23
3. Water removal .....	P24
Warranty / Repair .....	P25



Store this manual where it can be easily accessed.

If you have any questions, please contact your supplier or us.

## Important

### To operate the pump safely and correctly

- Please read and follow the safety precautions to avoid injury and property damage.
- Please follow the important safety related notes described in this section.
- Symbols and their meanings are as follows:

	Warning	Incompliance with the warning may lead to serious injury or death.
	Caution	Incompliance with the caution may lead to injury or damage to the pump.

### Symbols



This symbol indicates a warning or precaution. The specific warning is indicated in  $\Delta$ .



This symbol indicates a prohibited action. The specific prohibition is indicated in or near the symbol.



This symbol indicates a required action.

# Safety precautions



## Warning



Power off

### ● Turn off the power.

Handling pumps with power on may cause an electric shock. When performing the procedure, turn off the power, and make pump and equipment stand.



### ● Stop operation.

When feeling any danger or irregularity during operation, stop the operation and re-start from the beginning.



Prohibited

### ● Using power source other than specified is prohibited.

Using the pump except for the voltage in the nameplate may cause breakdowns, fire or electric shock. Do not use any power source other than the specified.



Prohibited

### ● Liquid leakage.

Spilling liquid on the motor or wiring by mistake may lead to fire or electric shock. Install the pump at a place where it will not get wet.



Prohibited

### ● Damaged pump.

Using damaged pumps may cause short circuit or electric shock. Never use them.



Precaution

### ● Do not damage, modify or stretch the power supply cord.

Heating or placing heavy objects on the cord may cause damage, causing fire or electric shock.



Connect  
Earth ground

### ● Connect the earth cable.

Using pumps without the earth cable may cause electric shock. Make sure to connect it.



Wear  
Protectors

### ● Wear protectors.

Direct contact with chemicals or liquids may be hazardous. When handling it, wear protectors such as a mask and gloves.



Prohibited

### ● Using pumps for purposes other than prescribed use is prohibited.

Using pumps for purposes other than prescribed use may cause injury or damage. Use the pump in accordance to its specifications.



Modification  
prohibited

### ● Modification of pumps is prohibited.

Modifying pumps is prohibited for danger. We are not responsible for any injury or damage due to the unauthorized modification.

# Safety precautions



## Warning



Prohibited

### ●Restrictions for handling pumps.

Do not make people use pumps without knowledge and perform the handling with full knowledge of them.



Precaution

### ●Ventilation.

In handling toxic or odorous liquids, it is at risk for intoxication. Well-ventilated is recommended.



Precaution

### ●Outflow protection.

Always take appropriate preventative measure to safeguard against liquid leakage in the event of breakdown of pump or piping.



Prohibited

### ●Using pumps around water is prohibited.

The pump is neither dust-proof nor waterproof. Using pumps under moist condition may cause electric shock or short-out.



Prohibited

### ●Dry running is prohibited.

Do not run dry (the state which pumps are operated without liquid inside). The friction generates the heat and causes damage of inside the pump.



Prohibited

### ●Pressurization to pumps is prohibited.

Do not pressurize inside the pump except for the pressure from the pump operation. It may cause liquid leakage from sealing of O-ring or pumps damage.



Electric Shock

### ●Circuit breaker (Selling separately).

Using pumps without circuit breaker may cause electric shock. It is recommended to install separately-purchased circuit breaker.



Electric Shock

### ●No exchange of power supply code.

The damaged code cannot be exchanged. If using it without change, electric shock or fire may occur. Handle the power code with care.



Prohibited

### ●Restrictions of installation / store. Do not install or store pumps as below.

- Location has a risk of fire
- Location of high temperature (over 40 degrees) or below zero.



### ●Disposal of used pump.

When disposing used pumps, follow the law of the disposal. (Ask the registered industrial waste disposer.)

# General description

For safe operation, check the purpose, limitation, hazard of pumps and use them correctly.

## 1. Unpacking check

Check them before use:

- (1) Check the pump is the same as your order. The model name, capacity, head and voltage are as noted your order.
- (2) Check no damage or missing parts.  
Check no damage during transportation or no loosen bolts by visually or hand-check.

\* For any defect, question or concern, ask your supplier.

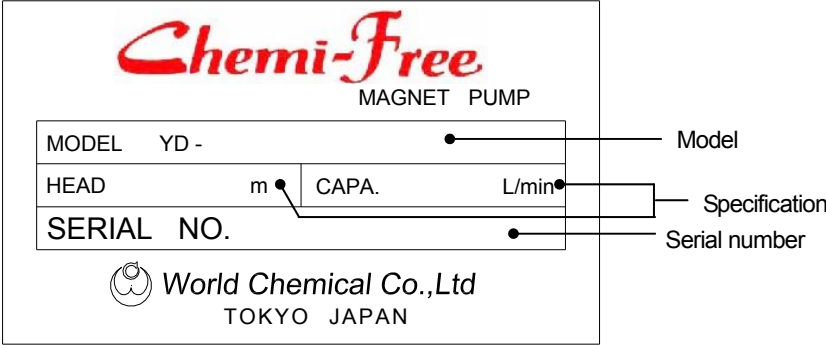

## 2. Operating principle

YD-GS model pump is a magnet-driven centrifugal pump. Rotation of a magnetically driven impeller in the pump chamber sends fluids from the intake to the discharge.

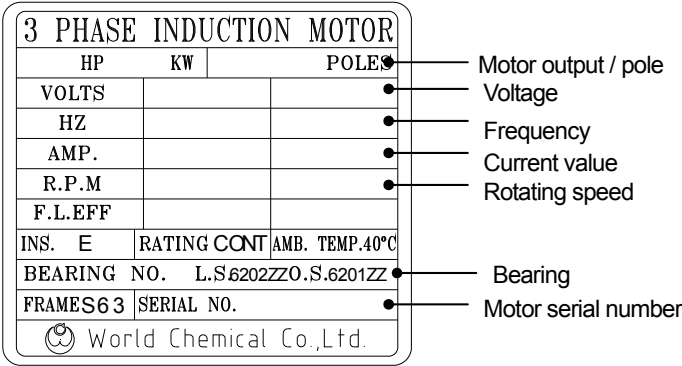

# General description

## 3. Model description

**YD- 16 X8 GS 1 – GP – R D 5 1 – SS**

	(1)	(2)	(3)	(4)	(5)	(6)	(7)	(8)	(9)	(10)
(1)	Discharge bore			16:16A	20:20A					
(2)	Motor output			X8: 0.18			A6: 0.26 (1ph)			
				Y6: 0.26						
(3)	Model			GS	GSH	GSF				
(4)	Motor type			1: IE1						
(5)	Main material			GP: GFR PP		CF: CFR ETFE				
(6)	Bearing material			R: CFR PTFE						
(7)	O-ring material			E: EPDM	F: EPM					
(8)	Frequency			5: 50Hz		6: 60Hz				
(9)	Limit of S.G.			1: 1.1	2: 1.2	4: 1.4				
(10)	Connection			FF: 25A flange		SS: G1 thread				
				UU: 20A union						

\* Union (20A x 20A) and flange (25A x 25A) are available as optional parts.

## 4. Specifications

(S.G.1.1)

Model	Performance (m <sup>3</sup> /min)		Max. head (m)		Max. capacity (t /min)		Motor		Weight (kg)	
	50Hz	60Hz	50Hz	60Hz	50Hz	60Hz	Rated power (w)	Voltage		
Standard	YD-16X8GS1	5-50	6.5-60	7.4	10.2	70	78	180/180	200V	6.2
	YD-20A6GS1	7-60	9.5-70	10.0	13.1	100	105	260/260	100V	8.9
	YD-20Y6GS1								200V	8.0
High pressure	YD-16A6GSH1	12-24	17-25	13.9	19.2	40	40	260/260	100V	8.9
	YD-16Y6GSH1								200V	8.0
	YD-20A6GSH1	9.5-70	-	12.7	-	104	-	260/-	100V	8.9
	YD-20Y6GSH1								200V	8.0

(S.G.1.2)

Standard	YD-16X8GSF1	5-60	5-60	8.2	8.7	90	91	180/180	200V	6.6
	YD-20A6GSF1								100V	9.2
	YD-20Y6GSF1	7.5-7.0	8-70	11	12	115	122	260/260	200V	8.3

### Note:

- The Test performance is with clear water at normal temperature.
- Max. capacity is the figure when the total head is 0 m. Max. total head means the total head.
- The limit of liquid viscosity (S.G. 1.0) is 30 mm<sup>2</sup> / s (30cSt).
- The range of the ambient temperature is from 0 degree to 40 degrees.
- The range of the ambient humid is from 35 to 85 %RH.
- The range of the liquid temperature to use  
GS = 0-70 degrees      GSF = 0-80 degrees  
However, it may be changed for the liquid and condition. (It is not used for frozen liquid.)
- The limit of S.G. is 1.1 at maximum. The figure is changed depending on the pump performance, ambient temperature or viscosity.
- YD-20GSH is for 50Hz only.
- Motor:      1PH condenser motor or 3PH motor.  
1PH/200V motor is also available as special.
- The motor (1PH 100V/110V, 3PH 200V/220V) is with a thermal protector.  
Operation temperature      1PH/ 3PH: 120±5 degrees
- There are an oil seal at the load side and a V-ring at the anti-load side inside to protect the motor from corrosive gas environment.
- The union type and flange type are as option. The nut, socket and O-ring for the union type / the O-ring for the flange type are attached. Refer the assembly procedure on Page 10, 12, 17.
- The performance or dimensions are subject to change without notice.

# General description

## 5. Performance Curve

16X8GS1 / 16Y(A)6GS1  
 20Y(A)6GS1 / 20Y(A)6GSH1  
 S.G. 1.1 (1.4)

50Hz

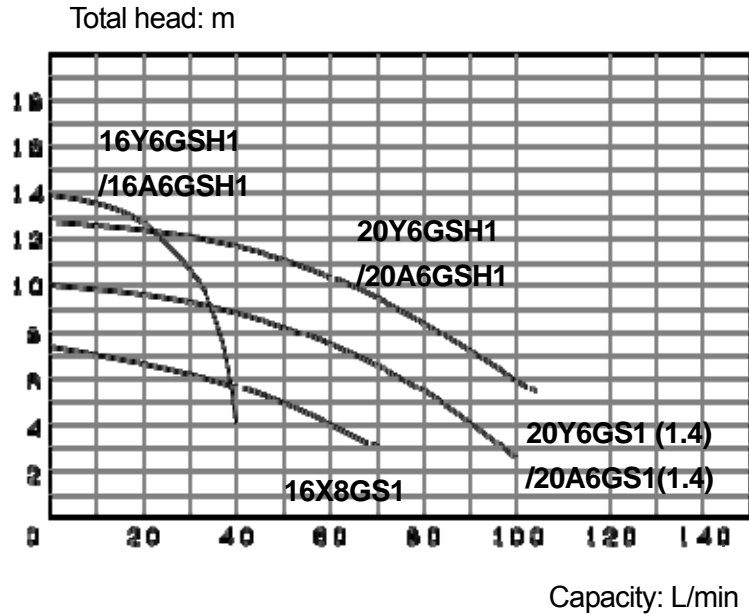

60Hz

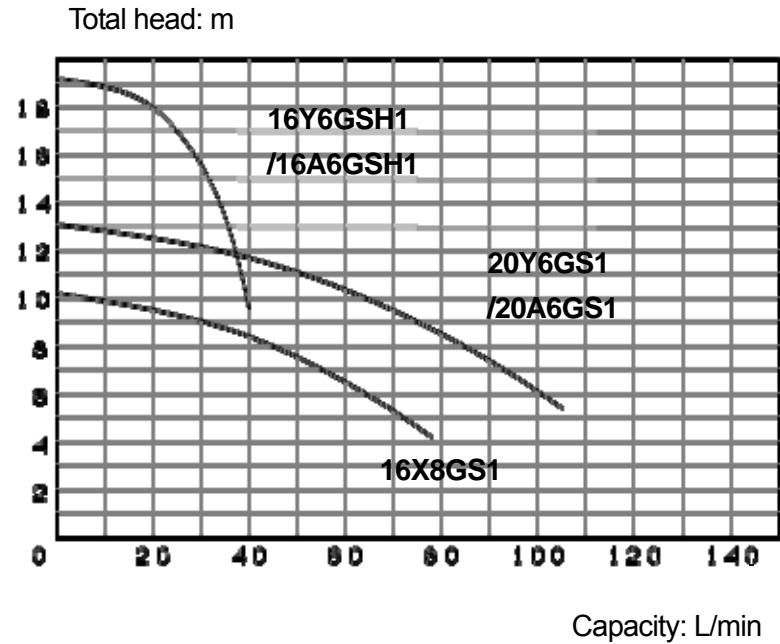

This performance test is based on JIS B 8301, 8302. The specific gravity of test liquid is 1.0.

# General description

16X8GSF1 / 20Y(A)6GSF  
S.G.1.2

50Hz

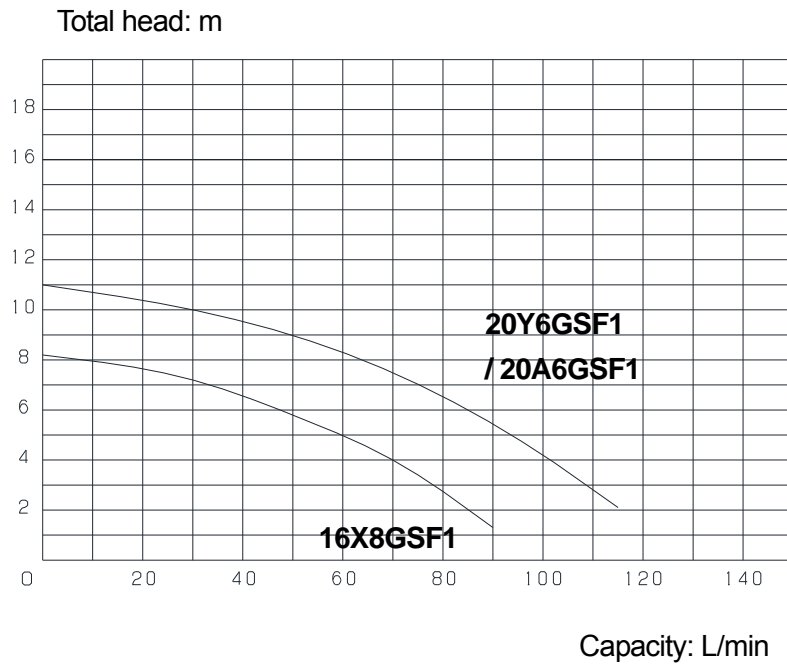

60Hz

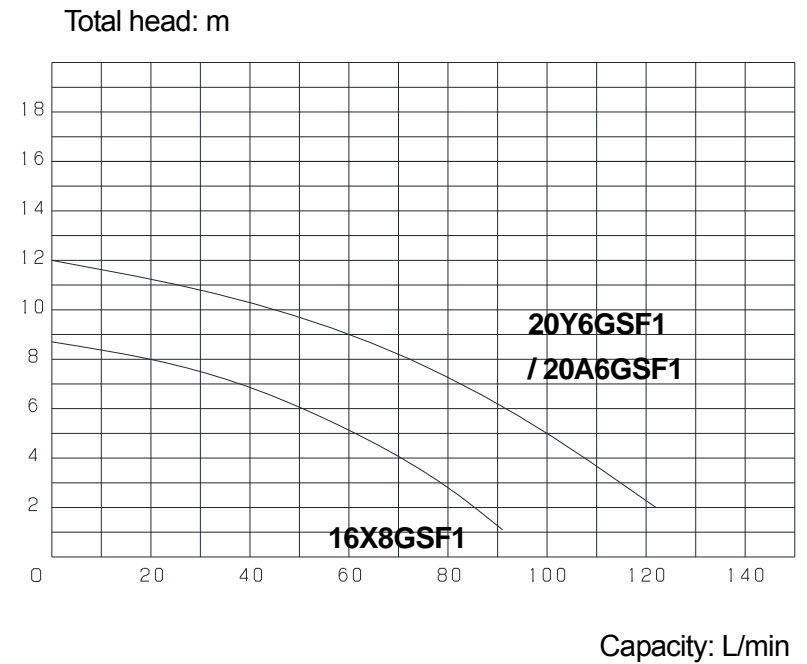

This performance test is based on JIS B 8301, 8302. The specific gravity of test liquid is 1.0.



# General description

16X8GSF / 20Y(A)6 GSF1  
S.G.1.5

50Hz

Total head: m

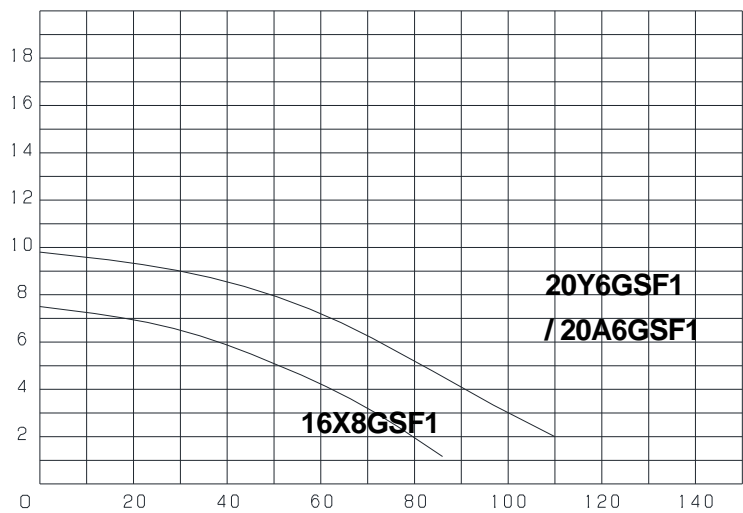

Capacity: L/min

60Hz

Total head: m

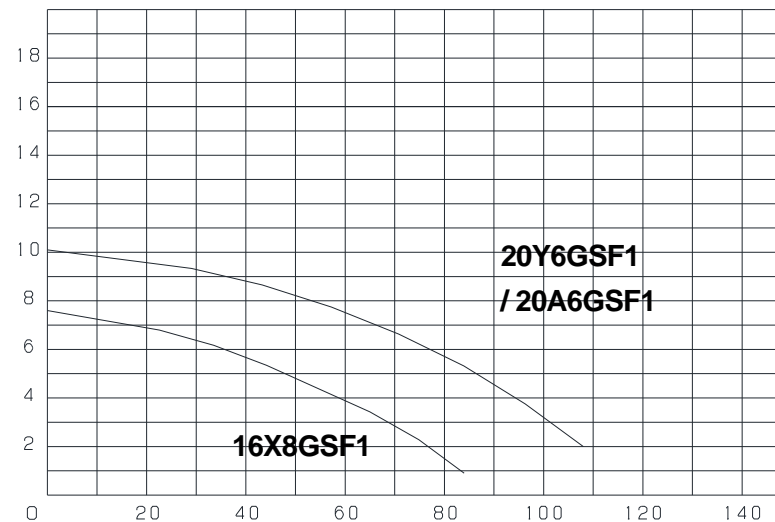

Capacity: L/min

This performance test is based on JIS B 8301, 8302. The specific gravity of test liquid is 1.0.

# General description

16X8 GSF/ 20Y(A)6 GSF1  
S.G.1.9

50Hz

Total head: m

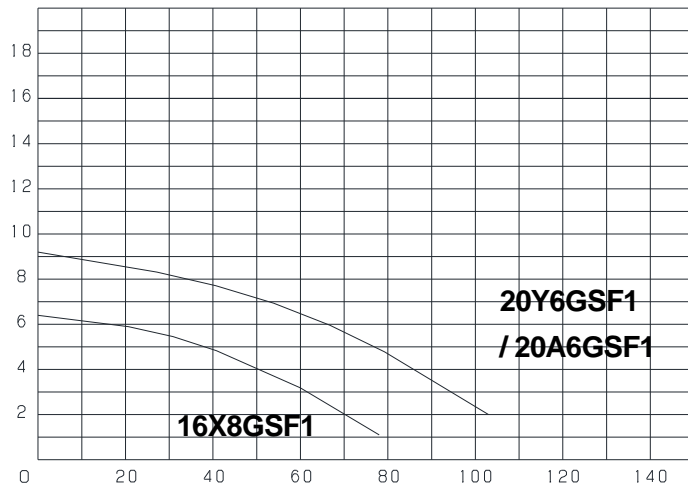

Capacity: L/min

60Hz

Total head: m

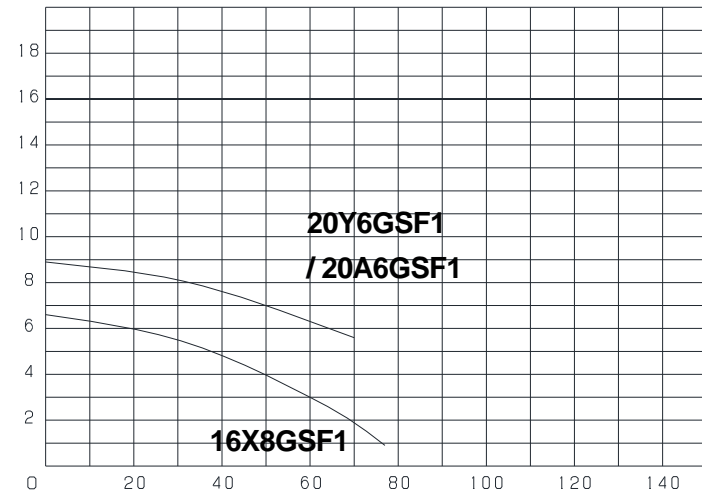

Capacity: L/min

This performance test is based on JIS B 8301, 8302 .The specific gravity of test liquid is 1.0.

# General description

## 6. Parts name / Structure

YD-16GS

YD-16GSF1

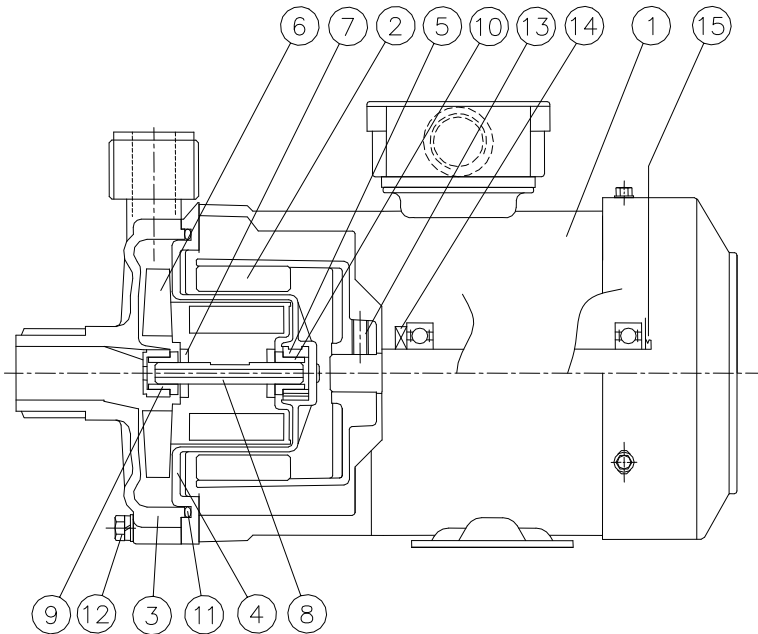

No.	PARTS NAME	QTY	MATERIAL		NOTE
			GS	GSF	
1	Motor (180W)	1			with Base
2	Outer Magnet	1	Ferrite Magnet / ADC 12		
3	Front casing	1	GFR PP	CFR ETFE	
4	Rear casing	1	GFR PP	CFR ETFE	
5	Bushing	1	GFR PPS	CFR ETFE	
6	Impeller	1	GFR PP+PP+Ferrite Mag.	CFR ETFE+Ferrite Mag.	
7	Thrust washer	2	Alumina Ceramics		
8	Shaft	1	Alumina Ceramics		
9	Front Bearing	1	PTFE		
10	Rear Bearing	1	PTFE		
11	O-ring (AS568-242)	1	FPWEPDM		
12	Hexagonal Bolt (M5*35)	6	SUS304		with Nuts & Bolts
13	Hexagonal Stud Bolts(M6*10)	2	SUS304		
14	Oil Seal	1	NBR		TC 30157
15	V-Ring	1	NBR		12A-φ11.5~φ12.5
Motor Bearing (LS: 6202ZZ, OS: 6201ZZ)					

# General description

YD-20GS1·20GSH1 (16GSH1)

YD-20GSF1

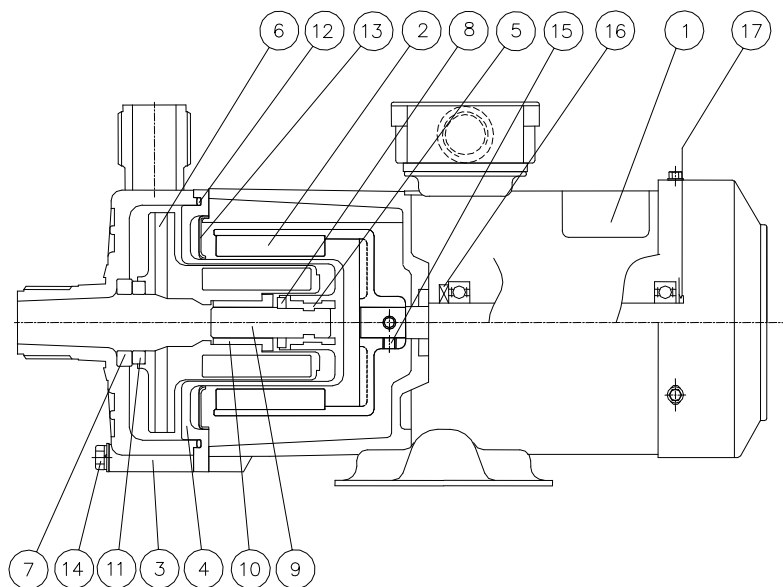

No.	PARTS NAME	QTY	MATERIAL		NOTE
			GS(H)	GS(H)F	
1	Motor (260W)	1			with Base
2	Outer Magnet	1	Ferrite Magnet / ADC 12		
3	Front Casing	1	GFR PP	CFR ETFE	
4	Rear Casing	1	GFR PP	CFR ETFE	
5	Bushing	1	GFR PPS	CFR ETFE	
6	Impeller	1	GFR PP+PP+Ferrite Mag.	CFR ETFE+Ferrite Mag.	
7	Front Thrust Washer	1	Alumina Ceramics		
8	Rear Thrust Washer	1	Alumina Ceramics		
9	Shaft	1	Alumina Ceramics		
10	Bearing	1	PTFE		
11	Thrust Ring	1	PTFE		
12	O-ring (G-110)	1	FPM/EPDM		
13	Back Up Ring	1	SPCC		
14	Hexagonal Bolt (M6*60)	6	SUS304		with Nuts & Bolts
15	Hexagonal Stud Bolts (M6*10)	2	SUS304		
16	Oil Seal	1	NBR		TC 30157
17	V-Ring	1	NBR		12A-φ11.5~φ12.5
	Motor Bearing (LS: 6202ZZ, OS: 6201ZZ)				

# General description

## 7. Outline Dimension

**YD-16GS1**   **YD-16GSF1**

Thread type

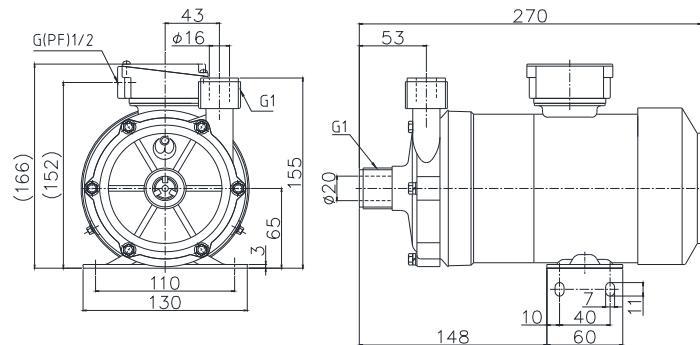

**YD-16GS1**   **YD-16GSF1**

Flange type

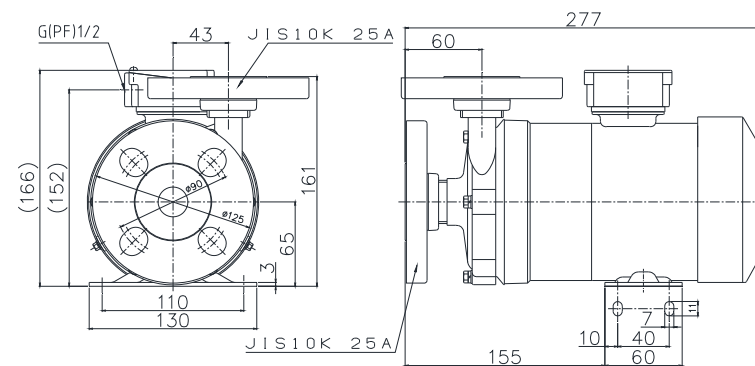

**YD-16GS1**   **YD-16GSF1**

Union type

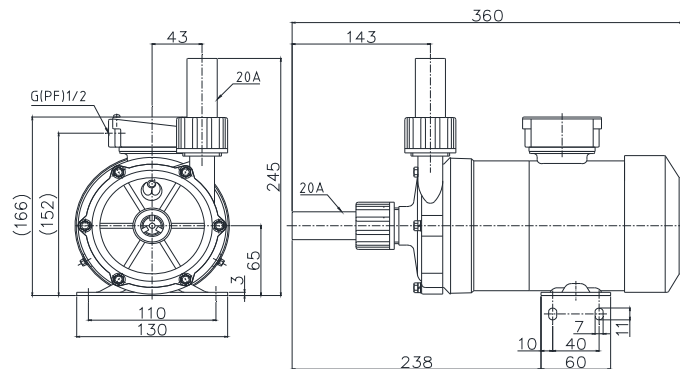

# General description

**YD-20GS1·20GSH 1(16GSH1)**

**YD-20GSF1**

Thread type

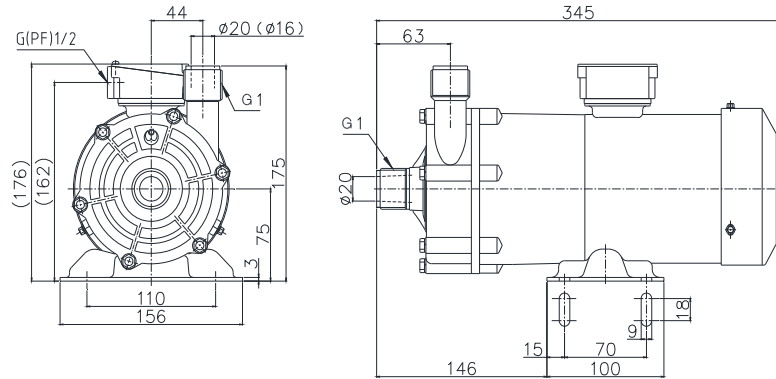

**YD-20GS1·20GSH1 (16GSH)1**

**YD-20GSF 1**

Flange type

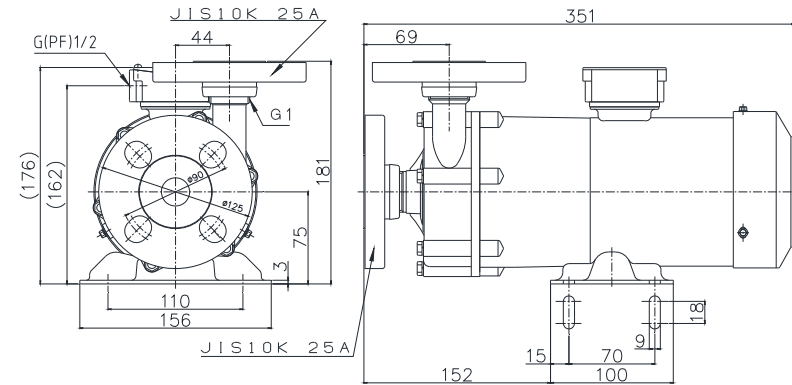

**YD-20GS1·YD-20GSH1 (16GSH1)**

**YD-20GSF1**

Union type

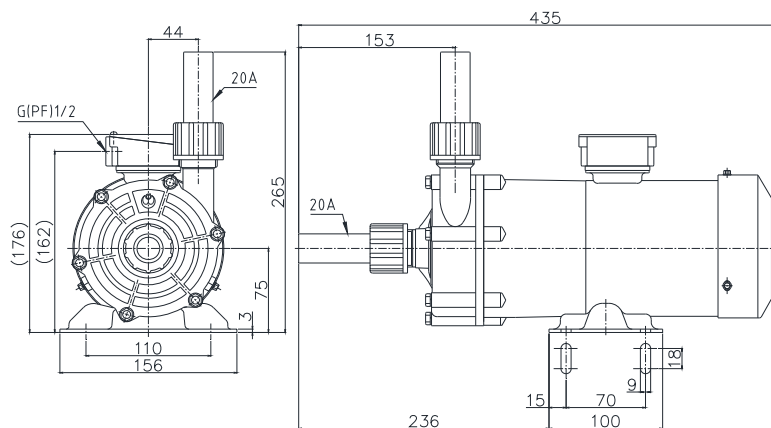

# Installation

## 1. Before operation

Handle pumps after reading and understanding the instruction manual completely.

### Warning

- When pumps or electric parts get wet by mistake, turn off the power. Direct contact may cause electric shock.
- No fire:  
For safety concerns, do not place any hazardous or combustible materials near pumps.

### Caution

- Since powerful magnets are inside, do not place any objects that are incompatible with magnetic force such as wristwatches, floppy discs or CD.
- Do not run dry. It may cause the frictional heat and parts damage.

- **Handle pumps with care.**

Do not drop or have a strong impact on pumps. It may cause damage or breakdown.

- **The pump is not self-priming type.**

Before operation, make sure to pour priming liquid and fill in the pump with liquid.

- **The pump is neither dust-proof nor waterproof**

Do not let the motor get wet.

- **Power supply cord**

Heating or placing heavy objects on the cord may cause damage and fire and/or electric shock. Do not modify, bend by constraint, stretch, twist or band it.

- **Banned liquid**

For details, contact us.

### Caution

- **Restrictions of installation / store.**

Do not install or store pumps as below.

- Locations with direct sunlight.
- High temperature locations (40°C and more)
- Dusty or humid places
- Locations below zero.
- Location exposed to the elements

# Installation

- Since powerful magnets are inside, the pump cannot be used for liquid with iron or nickel.
- Earth cable  
Connect the earth cable.
- Make sure to install the earth leakage circuit breaker to prevent unexpected electric shock.
- Maintenance and cleaning  
Do not use solvents such as benzene, alcohol or paint thinner, may cause paint to fade or peel.
- Damaged pumps  
Do not use damaged pumps to prevent short circuit or electric shock.

## 2. Installation / piping / wiring

When sensing any danger or irregularity during installation, stop the operation and re-start from the beginning.

### 2-1 Installation

- (1) Installation space  
The ambient temperature is from 0 to 40 degrees, the relative humidity is 90% or less and easy space for maintenance.
- (2) Installation  
The pump is not self-priming type.  
Install it lower than the liquid level in the suction tank.

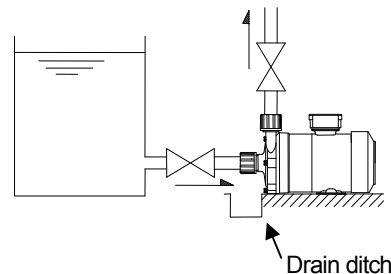

In this regard, if the liquid level from the suction inlet of the pump is too low, air enters, may cause pump failure. Make sure air not to enter. Become the height 30 mm as much as possible.

- (3) Direction of the discharge outlet  
Choice of the direction is possible, but it is recommended to set the discharge out let upward for easy air release.
- (4) Fixing the base  
Make sure to fix the base. Do not install the pump to a upward or downward direction.
- (5) Drain ditch  
Install a drain ditch for spilled liquid to flow to the process tank. If impossible, install a drain pan on instead.

### 2-2 Piping

#### (1) Tightening pipes

Use the bolt size as following list for the connection with the discharge / suction side and the flange side. Tighten them with appropriate torque evenly. (The following torque is for PVC flange and rubber gasket.)

Model	Bolt size	Torque (N·m (kgf·cm))
YD-16GS1 YD-20GS1	M16	19.6 (200)

#### (2) Suction pipe

- ① Be the suction pipe flooded suction type, short and less bending.  
Install the pipe support not to apply a load or thermal stress to the pump.



# Installation

- ② Install joints of the suction pipe not to air suction.  
If air enters into the suction pipe, it may cause pumping failure or damage.
- ③ Do not make projection space where air stays and install the pipe 1/100 and more up gradient to the pump.
- ④ When the bore between the suction inlet and suction pipe is different, Use a reducer. Connect the reducer to be the up evenly.
- ⑤ Make sure to use the bore of the suction pipe is bigger than the bore of the suction inlet of the pump.
- ⑥ It is recommended to install a gate valve at the suction pipe for easy disassemble maintenance. Make sure to fully open the valve during operation, because it is only for the maintenance.
- ⑦ When transferring hazardous liquid, install a flushing pipe for internal washing in consideration of the pump disassemble.
- ⑧ Install a screen at the suction inlet of the suction tank to prevent foreign objects enter. However, the screen is clogged depending on the liquid dirty or operating time proceeding, make sure to clean it periodically. If using the pump with clogged, it may cause the pump damage for the operation during air suction or dead head running.

## (3) Discharge pipe

- ① Install a support device to prevent the piping load to the pump.
- ② When the pipe is long, the piping resistance decreases and it may cause to be less than the expected performance. The piping bore is decided by calculating the piping resistance.

- ③ When the pipe has many bending within a short part, use the bore 1 size bigger than the discharge outlet. If the same, it may cause the piping pressure loss is big and expected pressure decreases. Especially, when using a spray pressure such as etching equipment, use the pipe 1 size bigger.
- ④ It is recommended to install check valves in the following. When selecting the check valves, consider the pressure limit of it. (Effects of the pump by water hammer or overflow)
  - 1) The discharge pipe is long.
  - 2) Total head is more than 10 m.
  - 3) The end of the discharge pipe is 9 m and more higher than the liquid level of the suction.
  - 4) 2 and more pumps are installed as parallel at the same pipe.
- ⑤ It is recommended to install sluice valves at the discharge pipe to adjust the capacity or prevent the motor overload. Meanwhile, when both check valves and sluice valves are installed, follow as state below, even if there are drawback and advantage.  
Pump → Check valve → Sluice valve
- ⑥ Make sure to install a pressure gauge at the discharge pipe.
- ⑦ When the discharge pipe is long in a horizontal direction, install air release on the way.
- ⑧ If the use liquid in the discharge pipe may freeze, install the drain to discharge the liquid in the discharge pipe.

## (4) Hose connection

- ① Be the hose short and less bending to prevent resistance for liquid. Furthermore, be the suction side hose thick and short to prevent cavitation (the phenomenon that bubble occurs).

# Installation

- ② Use the corrosive-resistant hose made of plastic which can be capable of the pump pressure.
- ③ Hose size (Bore:  $\Phi 26$ )  
Use it to fix to the pump bore. If not, the connection is failure. The suction side hose may be crashed by the suction force, so use a blade hose. (Especially, be careful to transfer hot water.)
- ④ Install valves  
Install valves between the hose connected to the pump and line.
  - Suction valve: It is easy to disassemble the pump and maintenance.
  - Discharge valve: For adjustment of the pump capacity.
- ⑤ Hose connection  
Push the hose to the discharge and suction side to the end.



## Caution

If the connection failure as the suction side, it may cause that air enters, pumping ability decreases, the pump run dry, the impeller is burned and the rotation becomes failure.

- ⑥ Fix the hose connection with the hose band firmly not to liquid leaks. Install it on the rib of the suction/discharge port.



## Caution

The connection is made of plastic and do not tighten excessively.

- ⑦ Do not apply the hose load at the suction / discharge port.

## (5) Union connection

- ① Install O-ring (P-22) in the ditch of the accompanying union sockets (20A, C-TVC) and screw it to the front casing with union nuts (GFR PP).
- ② Adjust the surface the union socket and front casing flat and tighten the O-ring evenly.

## (6) Flange connection

- ① Discharge side (upward)  
A loose flange, lap joint and O-ring are set.
- ② Suction side (sideways)  
A loose flange, lap joint and O-ring are set.

## 2-3 Wiring

Handle electric works by qualified person. If not, it may cause personal injury and property damage. If necessary, consult your supplier or us.

### ■ Before wiring

- (1) Check no power supplied before working.
- (2) Regarding wiring, subject to the electric code. (Use good wiring devices and subject to Electrical Equipment Technical Standards and Extension provisions.)

# Installation

- (3) Use the power supply indicated on the performance label.
- (4) There is ON/OFF switch on the pump. When supply the power by connecting the power supply code, the pump starts.
- (5) Prepare the earth code and connect it to the earth code of the motor. Select the pump install place where is well-ventilated and the pump does not get wet even if liquid spills.
- (6) When installing the short circuit breaker  
When a circuit breaker works, re-start the pump after the cause is prevented. When checking the cause, make sure to turn off the power.
- (7) When using the pump outside, wire by using a water proof cable clamp at the service entrance to prevent water rain enters.

### Motor / Rated current value / Starting current value

Model	Rated current (50Hz / 60Hz)			Starting current (50Hz / 60Hz)		
	100V (Single phase)	200V (Three phase)	220V/60Hz (Three phase)	200V (Single phase)	200V (Three phase)	220V / 60Hz (Three phase)
180W	-	1.03A/0.99A	0.93A	-	4.66A/4.61A	5.21A
260W	4.8A/4.5A	1.32A/1.26A	1.22A	24.5A/22.0A	6.09A/5.69A	6.32A

# Operation

## 1. Operation procedure

### Caution

- Check to install the pump securely before operation.
- Since any foreign objects enter the pump, turn off the power and remove them. If it now stands, it may cause damage or breakdown.
- Do not run dry (pumping without liquid). No liquid generates friction heat and it may cause the parts damage.

- (1) Check that hose and pipes at the discharge outlet and suction inlet are fixed securely before operation.
- (2) Do not operate the pump at the state of the discharge / suction valve closed or near closed.

The minimum flow rate is 5 L/min and more for the operation.

- (3) Do not close or open the discharge outlet and suction inlet suddenly. The magnet coupling comes off and the impeller may not rotate. (In this case, turn off the power. The motor stops and the coupling connects.)
- (4) Do not exceed the pressure limit of the pump discharge pressure as follows.

16GS(F)1 : 0.15MPa

20GS(F)1, 20GSH1 : 0.28MPa

16GSH1 : 0.30MPa

### ■ Operation

Operate the pump as the following procedure after installation, piping and wiring.

- There is ON/OFF switch on the pump. It starts when the power is supplied by connecting the power supply code.

No.	Operating procedure	Check list
1	<b>Check piping, wiring and the voltage.</b>	<ul style="list-style-type: none"> <li>● Check the article, "piping" and "wiring".</li> <li>● Check the voltage is correct by comparing the specification label.</li> </ul>
2	<b>Open or close valves.</b>	<ul style="list-style-type: none"> <li>● Suction valve : Full open</li> <li>● Discharge valve : Full open</li> </ul>
3	<b>Check the pump is full of liquid.</b>	<ul style="list-style-type: none"> <li>● Fill the pump with priming liquid (used liquid).</li> </ul>
4	<b>Check the rotation direction. (Turn on and immediately turn off the power.)</b>	<ul style="list-style-type: none"> <li>● Turn on the power to start the pump and check for the pump rotation direction. Look through the fan cover to check if the motor fan is rotating in the direction of the labeled arrow that appears on the motor (clockwise as viewed from the motor fan). Check the motor fan stops smoothly when turning off the power.</li> </ul> <p> <b>Caution</b> If the motor fan does not stop smoothly, something happens wrong. Check the inside.</p>
5	<b>Turn on the power.</b>	<ul style="list-style-type: none"> <li>● Check above 1 to 4 and turn on the power to start operation.</li> </ul>

# Operation

No.	Operating procedure	Check list
6	<b>Adjust the capacity and total head to the predetermined value.</b>	<ul style="list-style-type: none"> <li>Gradually adjust the discharge valve to the predetermined value of the capacity and total head. Do not open or close them suddenly.</li> </ul> <p>Note) Do not close the discharge valve for 1 minute and more.</p> <p>Note) Check pumping normally. If not, turn off the power soon and follow "Troubleshooting" (P22) and eliminate the cause.</p>
7	<b>Caution during operation.</b>	<ul style="list-style-type: none"> <li>Keep foreign objects out from the pump. When foreign objects enters, the impeller may be locked and cause pump failure. Even if the motor is locked, it can rotate. However, when it happens, turn off the power soon. (consult us.)</li> <li>If the circuit breaker works, turn off the power and follow "Troubleshooting" (P22) to check the cause.</li> </ul>

## ■ Shutdown

No.	Shutdown procedure	Check list
1	<b>Turn off the power. (Check the pump stop.)</b>	Check the motor stops slowly and smoothly when turning of the power. If not, it is necessary to check the pump. (Contact us.)
2	<b>Close the discharge valve.</b>	Gradually close the discharge valve. Do not close it suddenly by magnetic valves.

## ■ Caution for a long-time rest

If the pump is to be shut down for a long time, withdraw the liquid inside. Operate the pump with water for about 5 minutes once 3 months to prevent the motor bearing corrosion.

# Maintenance

## Exploded view

16GSH1/20GS(F)1/20GSH1

Flange set:

Loose flange

+ Lap joint

+ O-ring for flange

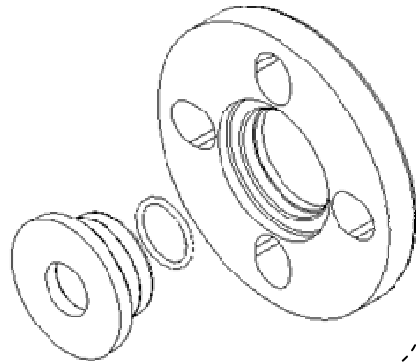

Union set:

Union socket

+ O-ring for union

+ Union nut

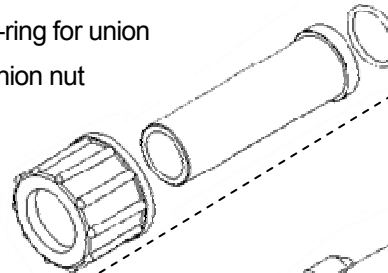

(12) O-ring for casing

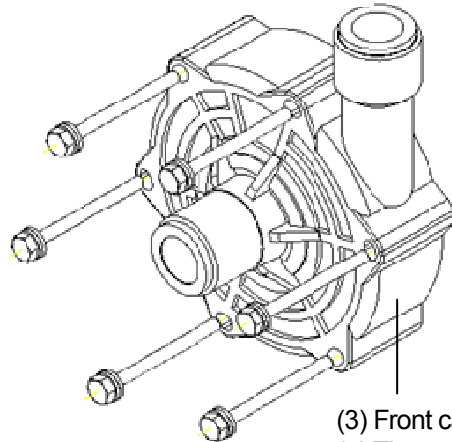

(3) Front casing +  
(7) Thrust washer

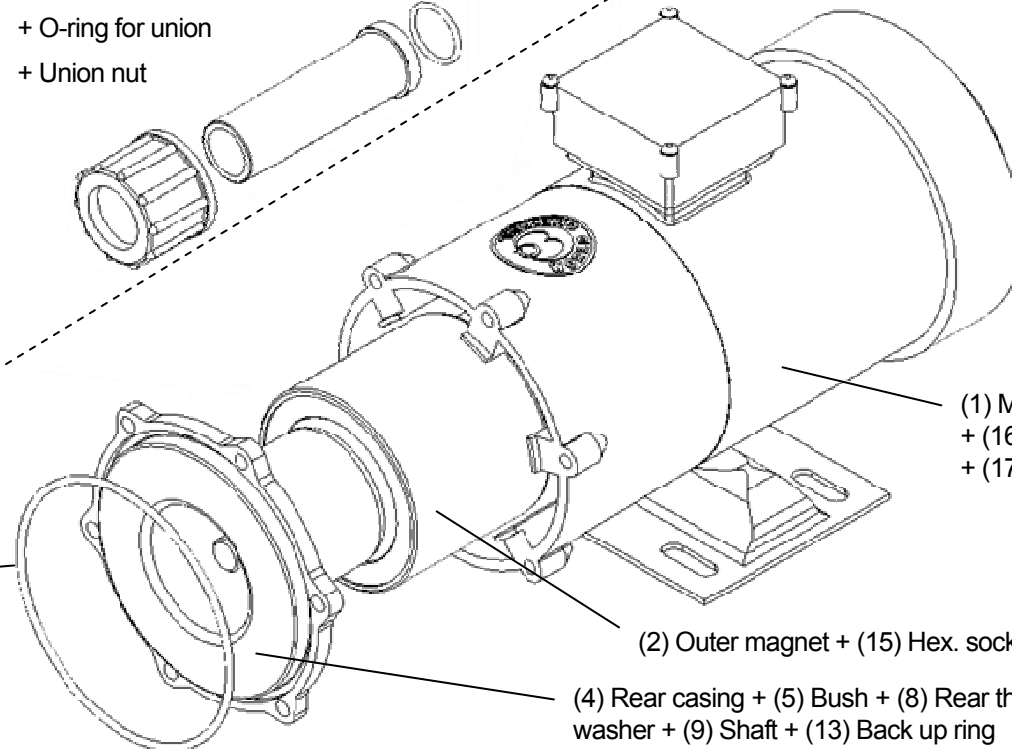

(1) Motor (260W)  
+ (16) Oil seal  
+ (17) V-ring

(2) Outer magnet + (15) Hex. socket set screw

(4) Rear casing + (5) Bush + (8) Rear thrust  
washer + (9) Shaft + (13) Back up ring

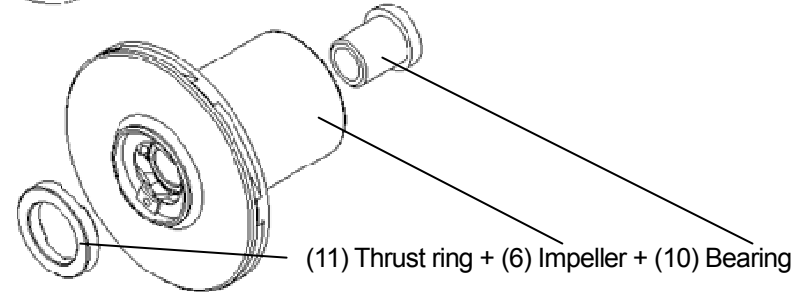

(11) Thrust ring + (6) Impeller + (10) Bearing

# Maintenance

## Exploded view

16GS(F)1

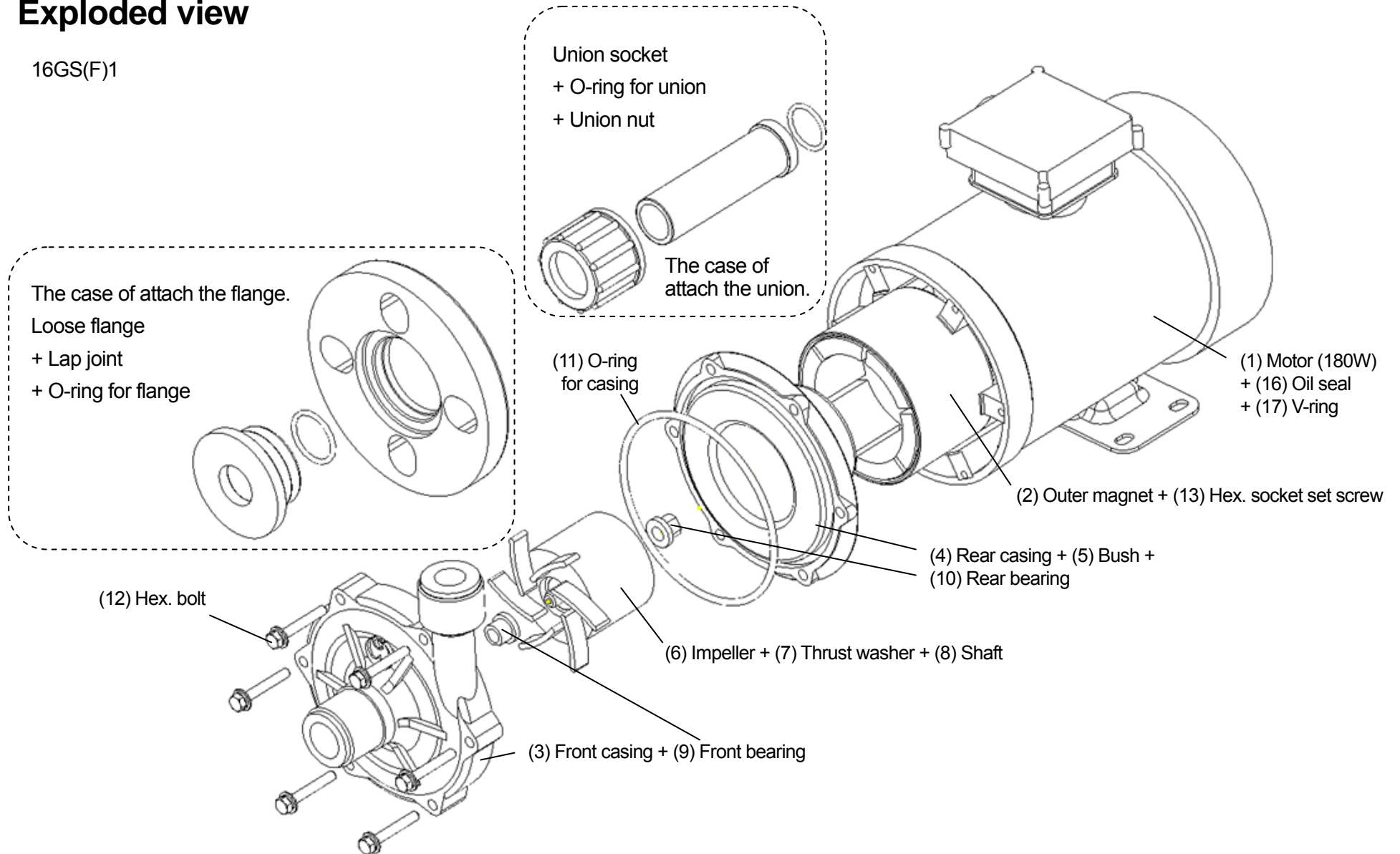

# Maintenance

## 1. Troubleshooting

TROUBLE	PUMP INDICATIONS		CAUSE	CHECK LIST AND ACTION(S) TO BE TAKEN	
	When discharge valve is shut off	When discharge valve is opened			
No Discharge		Pressure and vacuum gauge showing zero	<ul style="list-style-type: none"> <li>Not enough priming liquid</li> <li>Pump runs idle</li> </ul>	<ul style="list-style-type: none"> <li>Stop the pump and fill with enough liquid, then restart</li> </ul>	
	Priming liquid does not go into the pump		<ul style="list-style-type: none"> <li>Intake screen is clogged</li> <li>improper intake piping</li> <li>Lowering of the liquid surface level inside the intake reservoir</li> </ul>	<ul style="list-style-type: none"> <li>Clean the screen</li> <li>Check for any valve closure or screen obstruction</li> <li>Check for liquid surface level in intake reservoir, and raise the surface to a satisfactory level</li> </ul>	
	After the pump starts, the pressure would drop after discharge valve is opened	Pressure and vacuum gauge show sudden fluctuation and drooped to zero	<ul style="list-style-type: none"> <li>Air entering through intake pipe or gasket</li> </ul>	<ul style="list-style-type: none"> <li>Check the intake for any gap</li> <li>Check for any abnormally low liquid surface</li> <li>Make sure voltage is normal</li> </ul>	
	No discharge after restarting the pump following a shutdown	No discharge after restarting the pump following a shutdown	<ul style="list-style-type: none"> <li>Air lock, air accumulation in the intake pipe</li> </ul>	<ul style="list-style-type: none"> <li>Release air in the pipe</li> <li>Inspect piping and modify air pocket section</li> <li>Make sure air mixed in the backflow liquid can be smoothly drawn back into the intake reservoir, improve the piping incline; clean the screen</li> </ul>	
	Pressure gauge reading remain low at all time		<ul style="list-style-type: none"> <li>Pump rpm not enough</li> <li>Pump rotating in the wrong direction</li> </ul>	<ul style="list-style-type: none"> <li>Inspect wiring and motor, and take appropriate measures</li> <li>Replace wiring</li> </ul>	
Discharge Output Not Enough		High vacuum gauge reading	<ul style="list-style-type: none"> <li>Clogged screen is obstructing in the intake pipe</li> </ul>	<ul style="list-style-type: none"> <li>Clean the clogged screen</li> </ul>	
	Pressure gauge and vacuum gauge showing optimum readings		Very high vacuum gauge reading	<ul style="list-style-type: none"> <li>Air accumulating in the intake pipe</li> </ul>	<ul style="list-style-type: none"> <li>Inspect intake pipe installation and make modification if necessary</li> </ul>
				<ul style="list-style-type: none"> <li>The entrance to impeller is clogged</li> </ul>	<ul style="list-style-type: none"> <li>Remove foreign objects</li> </ul>
			Pressure and vacuum gauge show fluctuation	<ul style="list-style-type: none"> <li>Air entering through intake pipe or gasket</li> </ul>	<ul style="list-style-type: none"> <li>Inspect intake pipe joints and tighten if necessary</li> </ul>
				<ul style="list-style-type: none"> <li>Foreign object obstructing the discharge</li> </ul>	<ul style="list-style-type: none"> <li>Remove foreign objects inside the pump</li> <li>Remove obstructions or scale in pipe</li> </ul>
			High vacuum gauge reading but normal pressure reading	<ul style="list-style-type: none"> <li>Air pocket or other obstruction in the intake pipe</li> </ul>	<ul style="list-style-type: none"> <li>Check for any arched section on the intake pipe and take appropriate action</li> </ul>
			High pressure gauge reading but normal vacuum	<ul style="list-style-type: none"> <li>There may be a section of the discharge pipe giving high resistance or the actual pump height of pressure loss is too great.</li> </ul>	<ul style="list-style-type: none"> <li>Check for the actual pump height or pressure loss in the discharge pipe and take appropriate action</li> </ul>
	Low pressure gauge reading and very low vacuum gauge reading	Low pressure gauge reading and vacuum gauge reading also low	<ul style="list-style-type: none"> <li>Reverse rotation</li> </ul>	<ul style="list-style-type: none"> <li>Replace wiring</li> </ul>	
Motor Heats Up			<ul style="list-style-type: none"> <li>Whirling pressure dropped</li> <li>Overload</li> <li>High ambient temperature</li> </ul>	<ul style="list-style-type: none"> <li>Make sure the voltage and Hz are appropriate</li> <li>Make sure the liquid specific gravity and viscosity are appropriate</li> <li>Improve ventilation</li> </ul>	
Sudden Loss of Discharge Output		High vacuum gauge reading	<ul style="list-style-type: none"> <li>Screen clogged by foreign objects</li> </ul>	<ul style="list-style-type: none"> <li>Remove foreign objects</li> </ul>	
Pump Vibrates			<ul style="list-style-type: none"> <li>Base defect</li> <li>Loose bolt</li> <li>Closed intake pipe, cavitation in the intake pipe</li> <li>Impeller comes into contact with casing</li> <li>Worm motor bearing</li> </ul>	<ul style="list-style-type: none"> <li>Make sure installation is done appropriately</li> <li>Tighten the serews</li> <li>Clean or remove the cause for cavitation</li> <li>Remove the cause or replace</li> <li>Replice bearing or motor</li> </ul>	



# Maintenance

## 2. Maintenance / Check

### 2-1 Maintenance

#### ■ Bolt tightening

If the pump is not used for a long time, bolts may be loosened. Tighten the bolts not to plastic become deformed. Tighten them for long store as well.

The tightening torque is as follows:

**16GS1, 16GSH1, 20GS1, 20GSH1** : 2.4N·m

**16GSF1, 20GSF1** : 3.5N·m

### 2-2 Check

#### ■ Daily check

Check the operating state (no vibration, no abnormal noise) and no abnormal current value / capacity. If abnormality occurs, turn off the power soon and refer “Troubleshooting” to remove the cause.

#### ■ Replacement parts (Consumable parts)

It is necessary appropriate replacement parts to replace when the continuous operation for a long time. Especially consumable parts such as the impeller or O-rings are always available to sell. For more information, contact us.

#### ■ Recommended value to replace sliding parts for worn-out.

Model	Shaft	Bearing	Thrust Washer	Thrust Bearing
16GS(F)1	φ7	φ9	Worn by 1mm	Worn by 1mm
20GS(F)1 20GSH1 16GSH1	φ13	φ15	Worn by 1mm	Worn by 1mm

(Note)

Regarding the shaft / bearing, thrust washer / thrust bearing, total worn-out value of both parts, and when the worn-out value is 1 mm and more, replace the parts whose worn-out value is bigger.

# Maintenance

## 3. Water removal

### Warning

- Remove water after the main power off.  
This time, wear the protector (Safety gloves, shoes, etc.).
- When handling hazardous liquid, make sure to protect with rubber gloves, goggle, etc.

### Caution

- When removing the hose, liquid flows out of the discharge outlet and suction inlet. Do not get wet the motor or electric parts by mistake.
- Discharge hazardous liquid from the pump to the tray or container , not the ground or floor directly.
- The motor is not dustproof or waterproof. Do not pour or get wet with liquid by mistake.

### ■ Water removal procedure

- (1) Turn off the power. Do not touch by other people while at work.
- (2) Close the discharge and suction valve fully.
- (3) Remove the pipes and hoses at the discharge and suction side.

### Caution

Be careful of the residual liquid in the pipe, hose and pump.

- (4) Withdraw bolts for the pump base and remove the pump.
- (5) Remove water. Hand down the suction inlet and discharge water to the tray or container.

# Warranty / Repair

## 1. Warranty period and coverage

- (1) The warranty period is a year from delivered out of our factory.
- (2) During warranty period, if the pump breaks down or damages in normal operating condition due to manufacturing defect(s), the failure parts are repaired free of charge.
- (3) The following breakdown or damage are repaired or replaced of worn out parts for compensation.
  - After the warranty period.
  - Improper use or safekeeping.
  - Use parts manufactured by others or unauthorized parts.
  - Repair or modification by others or unauthorized company.
  - Natural disaster or accidental force.
- (4) We cannot be responsible for the break down or damage of the customer-specified pump.
- (5) Irregularities or breakdowns due to chemical or hydrodynamic corrosion by liquid are not covered under the warranty. The material chosen at the time of the contract is only a recommendation. We do not guarantee the chemical resistance of the material.
- (6) If the determination of the cause for the breakdown or damage is questionable, it attribute to the negotiation between the customer and us.
- (7) Travel expenses incurred for non-warranted repair to a remote location are charged.
- (8) Expenses or other damage incurred as a result of breakdowns during operation are not covered under the warranty.

## 2. Repair

### (ATTENTION)

Consult your supplier for repair. Cleanse the wet parts kit thoroughly, when returning it.

If any abnormality occurs, stop the operation soon and check the pump. (Refer to “Troubleshooting”)

- (1) For a repair service, contact your supplier or us.
- (2) Read this manual thoroughly again before requesting a repair service.
- (3) For repair, apprise information as follows.
  - Model name and serial number
  - Use duration and situation
  - Damages parts and condition
  - Liquid (Name, Specific gravity, Temperature, Slurry)

If liquid leaks during transportation, it is very dangerous and make sure to clean inside thoroughly.

When ordering replaced parts, specify the name in the parts name list. Although, inform the parts' number and material, too.

Model:	
Purchase date:	Serial number:
Start date:	Supplier:



Comprehensive Manufacturer of Environmental Equipment  
Challenging the Liquid Transfer Technology,

**World Chemical Co., Ltd.**

---

Head Office	3F., ANTEX24 Bldg, 1-1-14, Taito. Taito-ku, Tokyo, 110-0016 Japan	TEL: 03-5818-5130	FAX: 03-5818-5131
Overseas department	3F., ANTEX24 Bldg, 1-1-14, Taito. Taito-ku, Tokyo, 110-0016 Japan	TEL : 03-5818-5131	FAX : 03-5818-5131
Nagoya Office	1F., EIKEI Bldg., 1-307, Yashirogaoka, Meitou-ku, Nagoya-shi, Aichi, 465-0051 Japan	TEL 052-701-1227	FAX 052-701-1250
Osaka Office	7F., KUJO Bldg., 1-27-6, Kujo, Nishi-ku, Osaka-shi, Osaka, 550-0027 Japan	TEL: 06-6584-3185	FAX: 06-6584-3160
Tsukuba Factory	6127-5, Onogo-machi, Joso-shi, Ibaraki, 300-2521 Japan	TEL 0297-24-1071	FAX 0297-24-1075
Worchemi Taiwan Co., Ltd.	No.915, Zhongshan Rd., Shengang Dist., Taichung City 42955, TAIWAN	TEL 886-4-2562-8358	FAX 886-4-2562-8351
World Chemical USA, Inc.	30 Hughes, Suite 203, Irvine, CA 92618 U.S.A.	TEL 1-949-462-0900	FAX 1-949-462-0999
Suzhou World Technology Co., Ltd.	402, Fu Yuan Road, Xiang Cheng Economic District, Su Zhou, China	TEL 86-0512-6579-8212	FAX 86-0512-6579-8215
URL: <a href="http://www.wccc.co.jp/en">http://www.wccc.co.jp/en</a>	E-mail: chemical @wcc.co.jp		