

CORROSION RESISTANT SELF-PRIMING PUMP

YD-NSF / SF series

INSTRUCTION MANUAL

Version: 180308

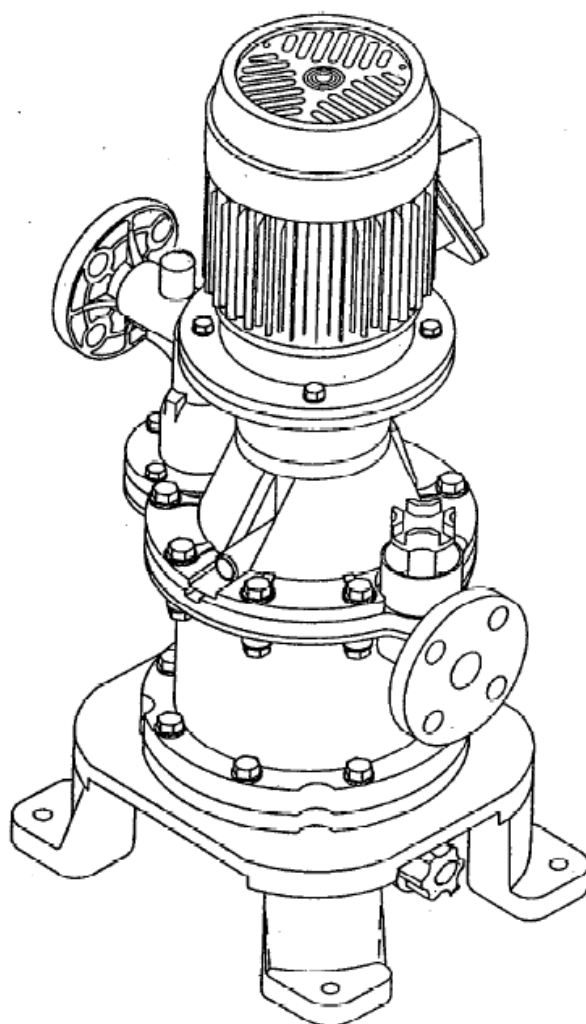

 **World Chemical Co., Ltd.**

Preface

Thank you for purchasing our corrosion-resistant self-priming pump “SELFREE Taf”. The pump can be used for high temperature non-electrolytic plating and general liquid. The standard model is a maintenance-free pump without mechanical seal or bearing.

It is necessary to operate and maintain the pump properly, so please read this instruction manual for the pump effectively and long-life.

Table of contents

Safety precaution (To be observed at all times).....	2
1. Features	4
2. Principle of self-priming	4
3. Performance	4
4. Structure & dimension	4
5. Model description	8
6. Standard performance	8
7. Disassembly / Assembly.....	9
8. YD-NSF-LR (Linear seal structure)	11
9. Handling precautions.....	11
10. Installing & piping	12
11. Troubleshooting.....	13

Safety precaution (To be observed at all times)



Warning

Dangerous liquid and surrounding

-  When using the pump for dangerous liquid or in potentially explosive atmospheres (only explosion-proof type), adhere to facility standards determined by law and check no liquid leak daily. If the pump is operated under abnormal conditions such as liquid leak, it leads to explosion, fire or personal injuries. Follow the manufacturers' instructions about handling the liquid.

Banning the use of damaged or modified pumps

If using the damaged or modified pump, it may cause personal injuries, electric shock or the pump damage. They are not covered by warranty.

Caution in transporting and lifting pumps

Use the hoist bolt when lifting a pump. If it does not own the hoist, use a belt sling and lift the pump with careful attention to the weight balance. Perform it by qualified personnel with the strong enough sling. The weight of the lightest pump is approx. 24kg at least. Do not carry a pump by hand as much as possible, because it may cause an accident.

Banning the operation with the power on

Do not check or disassemble a pump or motor while the power on. It leads to personal injuries from electric shock or getting caught in the rotor. Take the multiple safety precaution such as the switch for main power supply, the operation switch, and the hand switch for the pump.

Connection of an earth wire

Using the pump without connecting an earth wire may cause electric shock. Perform the connection by a qualified person according to the electric facilities technical standards and interior wiring regulations.

Protection of the power supply cord.

If stretching, pinching or damaging the power supply cords or motor lead wires, it causes fire or electric shock for the damaged cable. Install the cover of the terminal box in its proper position after wiring.

Ground Fault Interrupter (GFI)

If using a pump without a ground fault interrupter device, it may cause electric shock. Prevent the electric accidents and the pump damages applying circuit breakers, over-current protection devices and/or other protective devices.

Caution in removing a pump

When removing a pump from pipes, close the suction and discharge pipe valves and check no liquid leak. If direct contact with liquid, it may cause injury. Always wear protective gear when performing operations.

Caution



Banning the unspecified use

Do not use the pump for purposes other than those specified on the nameplate. Connect the pump after checking the power specification of motor (phase, voltage and frequency). Unspecified use may cause personal injuries or damages to the pump and peripheral equipment.



Restriction on persons handling a pump

Carry, install, wire, operate and maintain a pump by an expert who has full knowledge of the pump.



Caution in unpacking

Before opening the package, check the up side down. When it is a wooden crate, be careful to avoid injury yourself from nails and slivers.



Ventilation

Do not obstruct ventilation around the motor to prevent to overheat it. If handling toxic or odorous liquids, install the pump in a well-ventilated place to prevent symptoms of poisoning.



Repair and return

Contact your supplier or us to repair the damaged pump. When returning the pump by courier, clean up the inside and outside of the pump by water. Pack it with a plastic bag after checking no liquid.



Plastic parts

The pump is made of plastic. If it receives strong impact, it may damage and lead to personal injuries. Do no hit and climb on it. Install a piping support to prevent the piping load.



Pump start-up

Check the rotational direction when initially starting up the pump. Open the suction and discharge valves and check is no liquid leak from the pipe connection. Then, turn on the switch instantly after releasing air from the pipe and filling the liquid in the pump, and check the rotational direction. For reverse rotation, switch two of the three phases in the three-phase power supply. Before this, turn off the power supply and ensure safety.



Disposal of pump

When dispose the used pump, remove adhered liquid and dispose it as the industrial waste in accordance with the law.



Leak protection

Take appropriate preventative measures in consideration of possible leakage for the pump and pipe damage.

1. Features

- (1) The quality has a stabilized and the parts are timely supplied to be molded with commodity resin.
- (2) There is no sliding part for a Sealess pump. Easy maintenance and reasonable.
- (3) The wet parts kit, pump base and motor bracket are made of corrosion resistant resin. It does not corrode by chemical or atmospheric gases or spray.
- (4) The enclosed structure of the main body and special liquid seal structure are adopted to prevent liquid leak.
- (5) The heat resistant resin and absorption of thermal expansion structure are adopted, and it can be used for high temperature liquid.
- (6) The self-priming and suction ability is possible to pump when the liquid temperature is high.
- (7) "SELFREE Taf" is the same installing and piping dimensions as the previous pump.

2. Principle of self-priming

The priming water in the pump moves to the self-priming chamber by the impeller during start-up. Air and water are separated with circulation and water is pushed to the impeller through the self-priming hole. The self-priming ability occurs continuously. Air from the bearing is sealed by the seal blade and released to the self-priming chamber through the balance hole of the casing. The back flow by siphon action when the pump stops is cut off by the siphon cut hole between the self-priming chamber and the suction chamber. The enough self-priming water remains for the next self-priming action.

3. Performance

- (1) Standard performance

The standard performance curve (Normal temperature, clear water) is Picture 1 & 2. It is available to put 1 bigger motor output depending on the liquid specific gravity.

- (2) Performance for High temperature

Used liquid temperature: 0 – 90degrees (NSF series), 0-70 degrees (SF series)

The self-priming height, time and the pump ability is changed depending on the liquid temperature.

Consider the self-priming height. * The temperature is higher, the ability is decreased.

4. Structure & dimension

The structure is Picture 3. Parts list & Dimension table are List 1 &2.

- (1) Pump and pump bearing

The motor is modified and reinforced supervisory functions. The bearing is extended and the frequency is reduced. It is easy install and removal. Explosion-proof motor, overseas standards motor and non-standard motor aver available to assemble for the adoption of the standard bracket. In this case, the joint shaft with shaft clamp collar is adopted.

- (2) Absorption of thermal expansion

The main body extends to upward by thermal expansion, but the top is free and no restraint. On the other hand, the suction inlet and discharge outlet are restrained by pipes, but it can be alleviated by expansion joints and bending. It expands in millimeters units. The measures against thermal expansion for pipes are very important to protect the pump.

Picture 1: Standard performance (50Hz) S.G.1.05

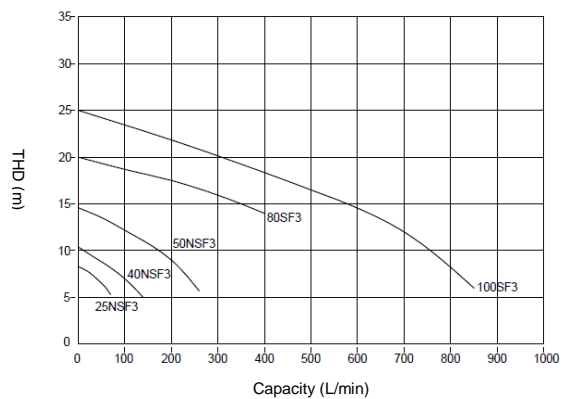

Picture 2: Standard performance (60Hz) S.G.1.05

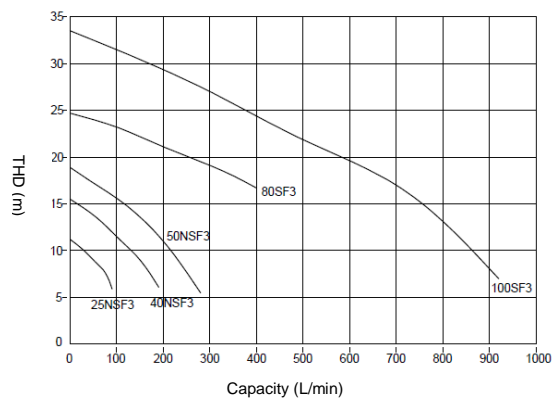

Self-priming limit against S.G. (Tem. 20 degrees)

Model \ S.G.	S.G.			
	1.0	1.1	1.3	1.5
YD-250*NSF (1)3	2.5m	2.3m	1.9m	1.7m
YD-400*NSF3	3.0m	2.7m	2.3m	2.0m
YD-500*NSF3	3.5m	3.2m	2.7m	2.3m
YD-800*SF3				
YD-100**SF3				

- The liquid temperature is 20 degrees. It is higher, the ability is lower.
- YD-250*NSF-LR type: S.G. is 1.0 and the limit of self-priming is 2.0m.

The motor output and applicable S.G. at standard performance (50Hz)

Model	Std. performance	0.4kW	0.75kW	1.5kW	2.2kW	3.7kW	5.5kW	7.5kW
YD-250*NSF(1)3	6m-60L/min	1.05	1.7	2.0	-	-	-	-
YD-400*NSF3	7m-100L/min	-	1.05	1.8	2.0	-	-	-
YD-500*NSF3	9m-200L/min	-	-	1.05	1.45	2.0	-	-
YD-800*SF3	15m-350L/min	-	-	-	-	1.05	1.5	-
YD-100**SF3	12m-700L/min	-	-	-	-	-	1.05	1.4

- The standard performance of YD-2502NSF3 is 7m-60L/min.

The motor output and applicable S.G. at standard performance (60Hz)

Model	Std. performance	0.75kW	1.5kW	2.2kW	3.7kW	5.5kW	7.5kW
YD-250*NSF(1)3	8m-70L/min	1.05	1.8	-	-	-	-
YD-400*NSF3	9m-150L/min	-	1.05	1.45	-	-	-
YD-500*NSF3	11m-200L/min	-	-	1.05	1.6	-	-
YD-800*SF3	18m-350L/min	-	-	-	-	1.05	1.35
YD-100**SF3	17m-700L/min	-	-	-	-	-	1.05

- The applicable specific gravity may be changed depending on the conditions.

[YD-NSF series]

Picture 3: Cross-sectional drawing

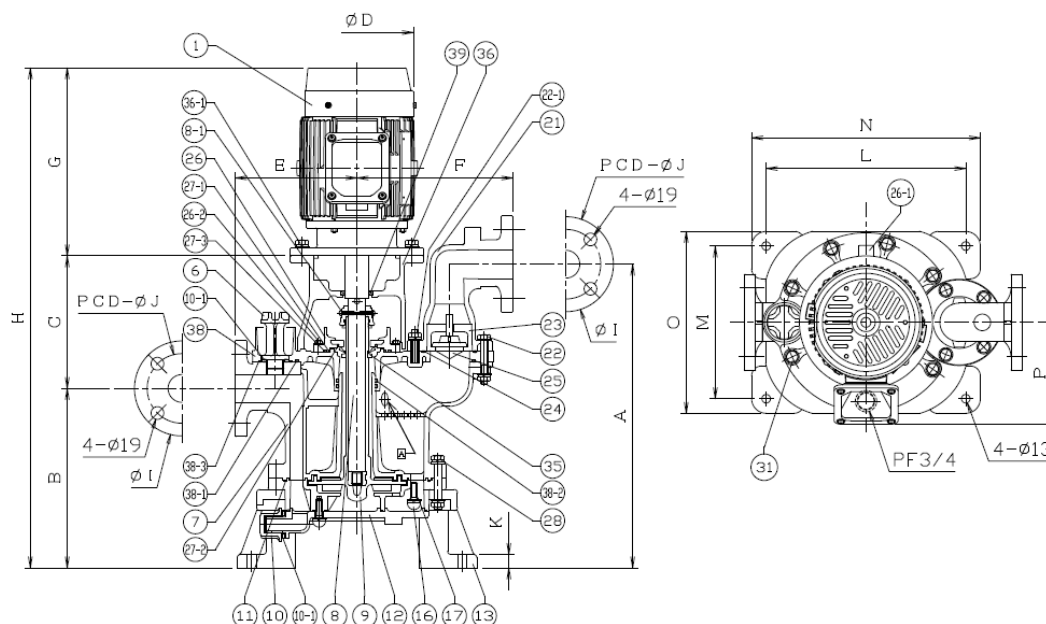

List 1: Parts list

1	Motor	1		25	Valve	1	CFR-PP
6	Water priming plug	1	CFR-PP	26	Seal case	1	CFR-PP
7	Main body	1	CFR-PP	26-1	Overflow pipe	1	HT.PVC
8	Shaft	1	SUS	26-2	Bolt for seal case	4	SUS
8-1	Bush	2	Diallyl	27-1	O-ring for seal case	1	EPDM/FPM
9	Impeller	1	CFR-PP	27-2	O-ring for seal case	1	EPDM/FPM
10	Drain cap	1	CFR-PP	27-3	O-ring for seal case	1	EPDM/FPM
10-1	Packing	1	EPDM/FPM	28	Bolt for pump body	8	SUS
11	O-ring for casing	1	EPDM/FPM	31	Bolt for bracket	8	SUS
12	Casing	1	CFR-PP	35	Dry seal	1	FPM
13	Pump base	1	Polyester	36	Bracket	1	Polyester
16	Bolt for casing	5	SUS	36-1	Bolt for motor	4	SUS
17	O-ring for pump body	5	EPDM/FPM	38	Upper flange	1	CFR-PP
21	Discharge elbow	1	CFR-PP	38-1	O-ring for upper flange	1	EPDM/FPM
22	Bolt for discharge elbow	4	SUS	38-2	O-ring for inner pipe	2	EPDM/FPM
22-1	Stud bolt	1	SUS	38-3	O-ring priming water	1	EPDM/FPM
23	Valve retainer	1	CFR-PP	39	Oil seal	1	NBR
24	O-ring for discahrge elbow	1	EPDM/FPM	* No. 27-3 is only for 40/50NSF3.			

List 2: Dimension table

Model	A	B	C	ΦD	E	F	G	H	ΦI	J	K	L	M	N	O	P
YD-2500NSF1	435	256	177	136	175	202	250	683	125	90	20	280	200	340	244	142
YD-2501NSF3	435	256	214	170	175	202	283	753	125	90	20	280	200	340	244	145.5
YD-2502NSF3	435	256	214	202	175	202	273	743	125	90	20	280	200	340	244	168
YD-4001NSF3	460	272	199	170	185	238	283	754	145	105	20	300	230	360	274	145.5
YD-4002NSF3	460	272	199	202	185	238	312	783	145	105	20	300	230	360	274	153
YD-4003NSF3	460	272	199	202	185	238	302	773	145	105	20	300	230	360	274	168
YD-5002NSF3	489	294	206	202	194	264	312	812	155	120	20	320	260	380	304	153
YD-5003NSF3	489	294	206	202	194	264	312	812	155	120	20	320	260	380	304	153
YD-5005NSF3	489	294	206	243	194	264	326	863	155	120	20	320	260	380	304	187

[YD-SF series]

Picture 3: Cross-sectional drawing

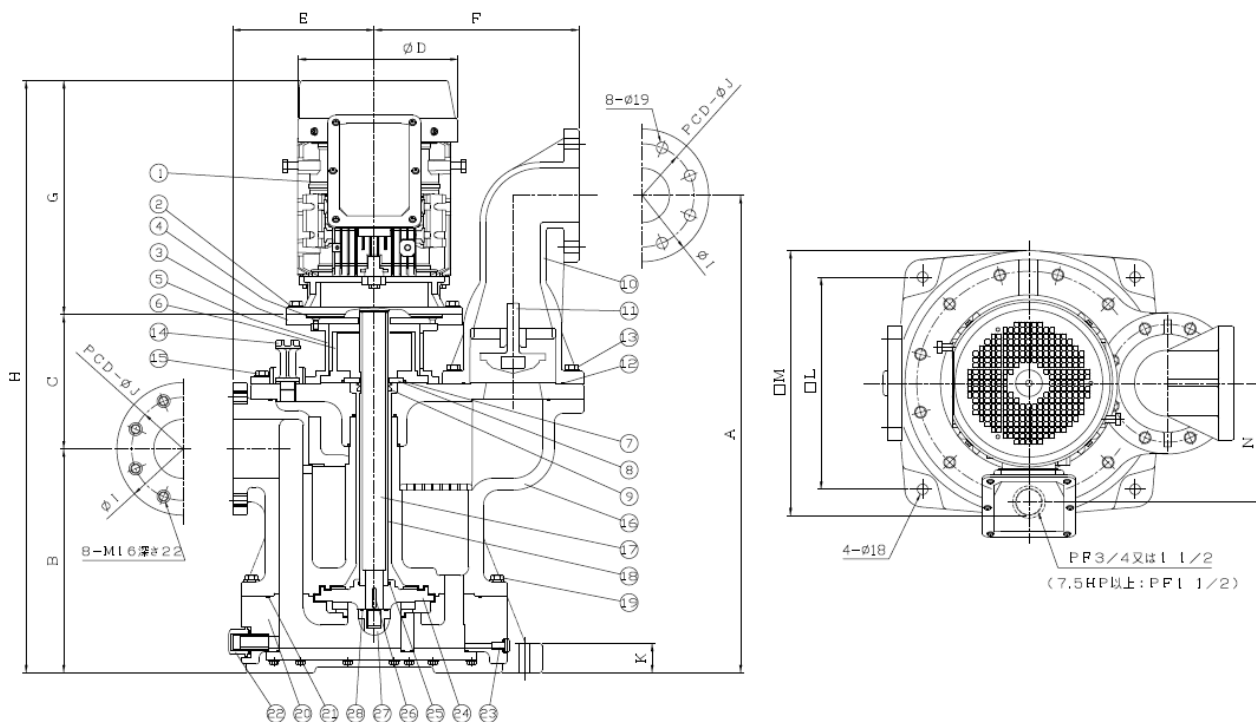

List 1: Parts list

1	Motor	1		15	Bolt for motor mount	10	SUS
2	Bolt for motor	4	SUS	16	Main body	1	Epoxy
3	Motor flange	1	SS400	17	Shaft	1	S45C+Hastelloy
4	Bolt for motor flange	6	SUS	18	Shaft sleeve	1	HT.PVC
5	Motor mount	1	SS400	19	Bolt for pump body	12	SUS
6	Seal case	1	HT.PVC	20	Casing	1	Epoxy
7	O-ring for seal case	1	EPDM/FPM	21	O-ring for casing	1	EPDM/FPM
8	Counter face ring	1	Carbon	22	Drain cap	1	CFR-PP
9	Dry seal	1	FPM	23	Drain bolt	1	CFR-PP
10	Discharge elbow	1	Epoxy	24	Impeller	1	HT.PVC
11	Valve	1	HT.PVC	25	O-ring for impeller	1	EPDM/FPM
12	O-ring for discharge elbow	1	EPDM/FPM	26	Impeller key	2	Titanium
13	Bolt for discharge elbow	8	SUS	27	Impeller nut	1	HT.PVC
14	Water priming plug	1	CFR-PP	28	O-ring for impeller nut	1	EPDM/FPM

List 2: Dimension table

Model	A	B	C	ΦD	E	F	G	H	ΦI	J	K	□L	□M	□N
YD-8005SF3	810	380	228	243	240	347	359	967	195	150	50	360	450	151.5
YD-8007SF3	810	380	228	285	240	347	397	1005	195	150	50	360	450	201.5
YD-8010SF3	810	380	228	285	240	347	397	1005	195	150	50	360	450	201.5
YD-10007SF3	810	380	228	285	240	347	397	1005	225	175	50	360	450	201.5
YD-10010SF3	810	380	228	285	240	347	397	1005	225	175	50	360	450	201.5

5. Model description

YD – 2501 NSF3 – CP – D D 5 7 – N

(1)

(2)

(3)

(4)

(5)

(6)

(7)

(8)

(1) Bore and Motor output

Model	Suction bore	Discharge bore	Output
YD-2500NSF1	25A	25A	0.4kW
YD-2501NSF3			0.75kW
YD-2502NSF3			1.5kW
YD-4001NSF3	40A	40A	0.75kW
YD-4002NSF3			1.5kW
YD-4003NSF3			2.2kW
YD-5002NSF3	50A	50A	1.5kW
YD-5003NSF3			2.2kW
YD-5005NSF3			3.7kW
YD-8005SF3	80A	80A	3.7kW
YD-8007SF3			5.5kW
YD-8010SF3			7.5kW
YD-10007SF3	100A	100A	5.5kW
YD-10010SF3			7.5kW

(2) Model name: NSF(1)3 SF3

(3) Material: CP: CFR-PP EP: Epoxy

(4) Dry seal material: D: Dry seal L: Linear seal

(5) O-ring material: E: EPDM D: FPM

(6) Frequency: 5: 50Hz 6: 60Hz

(7) Specific gravity: 1: 1.05 3: 1.35 4: 1.4/1.45 5: 1.5
6: 1.6 7: 1.7 8: 1.8 G: 2.0

(8) Inner O-ring: N: New type (Standard for only 40/50NSF)

6. Standard performance

Model	Standard performance (50Hz)	Standard performance (60Hz)	Weight (kg)
YD-2500NSF1	6m-60L/min	-	24
YD-2501NSF3		8m-70L/min	44
YD-2502NSF3	41		
YD-4001NSF3	7m-100L/min		48
YD-4002NSF3		9m-150L/min	50.5
YD-4003NSF3			58
YD-5002NSF3	9m-200L/min	11m-200L/min	55.5
YD-5003NSF3			56
YD-5005NSF3			72
YD-8005SF3	15m-350L/min	18m-350L/min	150
YD-8007SF3			178
YD-8010SF3	-		178
YD-10007SF3	12m-700L/min	17m-700L/min	203
YD-10010SF3			203

7. Disassembly / Assembly

- A. Remove the pump from the pipe and drain the liquid completely through the drain plug (10). Inject water through the suction inlet / discharge outlet and priming hole to wash the inside of the pump.
- B. Remove the pump base...
- (1) The pump is placed face down.
 - (2) Remove eight bolts (28) to fix the pump base (13) and remove the pump base.
- C. Disassembling the pump
- (1) Remove the five bolts (16) to fix the casing. When removing the casing (12), the impeller (9) appears. They are set with care of 5 O-rings for main body when installing parts.
 - (2) Remove the over flow pipe (26-1) from the seal case (26).
 - (3) Put a screwdriver in the hole at the top of the bracket and loosen the two small screws to fix two locking sleeves (8-1).
 - (4) Likewise, put a screwdriver in the hole at the top of the bracket and lock the shaft. Clip the impeller nut (9) with a spanner and turn it counterclockwise. Unscrew and take the impeller out.
 - (5) Remove the pump body (7), the upper flange (38) and the discharge elbow (21) together from the bracket by loosening eight bolts to fix the bracket (31).
- D. Disassembling the upper flange
- (1) Remove the water priming plug (6) from the pump body (7).
 - (2) Remove the discharge elbow by loosening bolts to fix the discharge elbow (22) (22-1).
 - (3) Remove the upper flange (38) from the pump body (7).
If it is hard to remove the upper flange because of the O-ring (38-2), use the two cuts beneath the upper flange to remove it.
 - (4) Remove the seal case (26) by loosening four bolts to fix seal case (26-2).
- E. Remove the motor bracket
- (1) Remove the two locking sleeves (8-1) from the shaft.
 - (2) The motor bracket (36) is removed by loosening four bolts to fix the motor (36-1).
- Caution: The motor bracket (36) and the pump bracket (37) are adhered and all-in-one. Never disassemble them.

The above completes disassembling the pump unit. Assembly is followed these steps in reverse.
All screws are tightened by turning clockwise.

The tightening torque as reference (Motor bracket, Pump base (casing): 150kgf·cm (14.7N·m)

YD-NSF: Exploded view

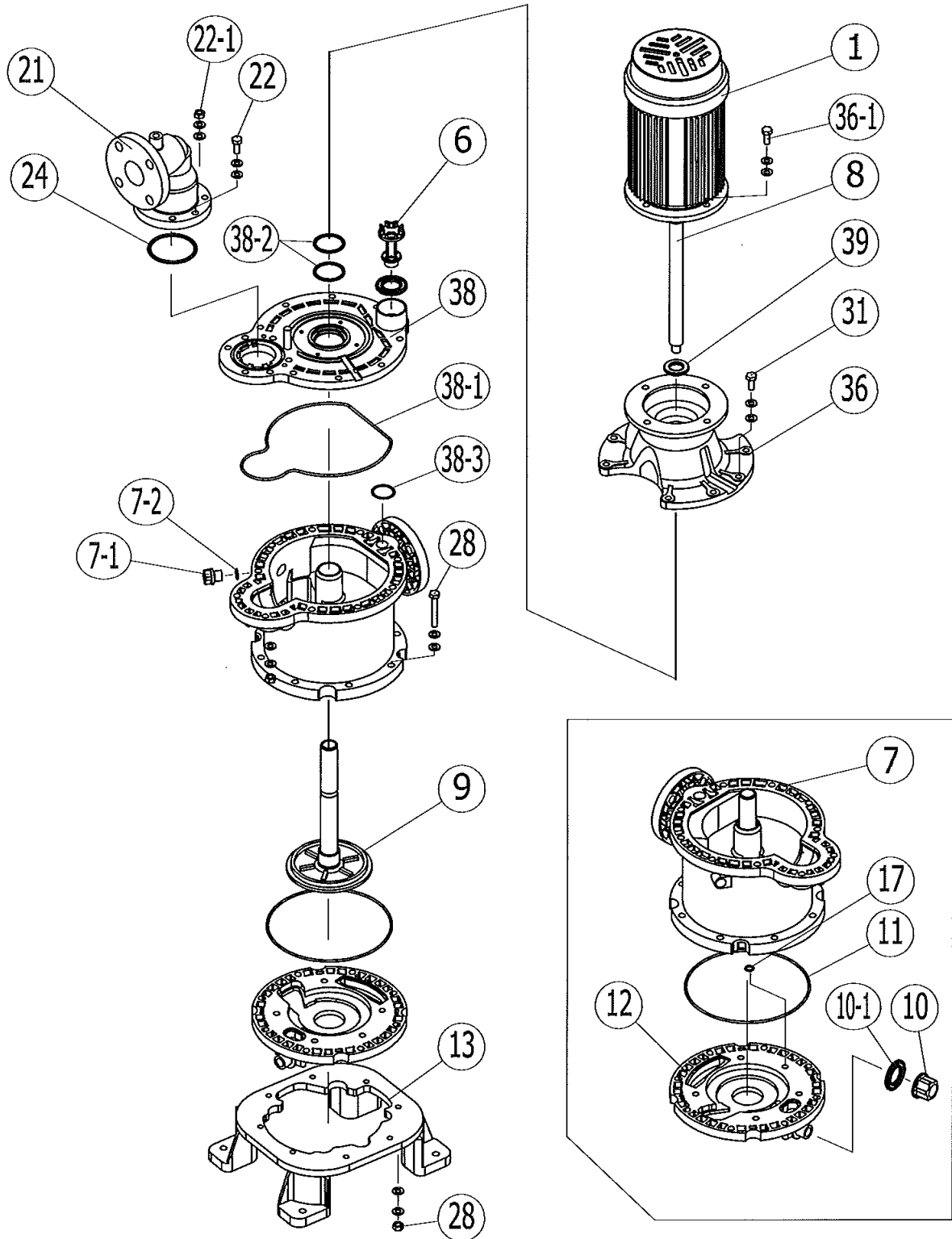

8. YD-NSF-LR (Linear seal structure)

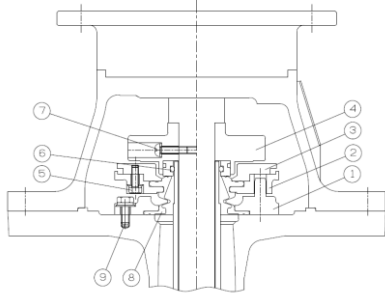

1	Movable seal base	CFR PP	1
2	Movable seal lower	CFR PP	1
3	Movable seal upper	CFR PP+Magnet	1
4	Rotating disk	CFR PP +Magnet+Ceramic	1
5	Hex. bolt	SUS	8
6	O-ring for rotating disk	FPM	1
7	Pan head screw	SUS	2
8	Phragm	FPM	1

General description

The pump can be operated as the end suction because of liquid sealing by the back-blade structure during operation and the linear seal when the operation stops, even if it is the Sealess structure.

- Linear seal

Linear seal is a shaft sealing to prevent liquid leaks when the pump stops. The sealing part is contactless-state during operation and there is no abrasion on the sealing part and no contact with liquid. It is a special sealing structure which is not affected by slurry.

The movable seal goes upwards when the pump stops and contacts with the rotating disk to seal liquid. The movable seal goes down when the pump starts, and the seal part is opened and contactless state. The state continues during operation.

Visually check that the movable seal goes down when the pump starts.

If not, it causes the sealing failure.

* Make sure to wear protectors because liquid may spill out for any error.

9. Handling precautions

- (1) Remove the bore stickers inlet and outlet of the pump before piping.
- (2) Do not rotate the pump backwards. (Except for checking the direction instantly.)
- (3) The structure is that a certain amount of liquid remains in the casing when the pump is stopped.
- (4) If liquid is easily bubbling, priming water may take a time or failure and it causes the pump damage.
- (5) If much slurry enters into the pump, it infills the back blade of the impeller and lose the sealing ability. It causes liquid leaks.
- (6) Liquid of high S.G. or temperature takes much time for self-priming and it is recommended to shorten the length of the suction pipe.
- (7) If much air enters, the self-priming failure occurs. If the pump continues to be operated for extended hours, it leads the deformation or burn out of the pump and casing to raise the liquid temperature.
- (8) Install a vertical pipe at the discharge side more than 1 meter and attach a bypass pipe for air release not to reduce the self-priming ability.
- (9) Shorten the suction pipe length to minimize the resistance loss.
- (10) The suction height is decreased depending on the type, specific gravity and temperature of the liquid. It is recommended to set it in consideration with the possible decrease.
- (11) It is recommended to place bending and expansion joints to prevent the deformation of the pump or liquid leak by the thermal expansion of pipes.

- (12) When using for waste liquid, install the strainer on the suction pipe to prevent foreign object.
- (13) When carrying the pump to change the installation site, repair or whatever, drain the liquid completely and wash the pump with water to ensure safety.
- (14) Handle the pump carefully not to make an impact, because of the resin base.
- (15) If the pump runs dry or liquid sealing by mistake, the inside may be high temperature. By this, if the priming plug or cock is opened, it spews the steam or hot liquid and is very dangerous. Make sure the temperature is fully-low and open it.

The minimum capacity of YD-25NSF1 (0.4kW) is 10L/min and other model is 20L/min during operation. Operate the pump with the capacity more than the above.

- (16) Turn on / off the pump is less than six times per hour. The frequent suspension strains the motor and the pump, and it may cause their damage.
- (17) Tighten the drain plug and the priming plug periodically. The looseness may lead to liquid leak or the incapability of self-priming.
- (18) If using an inverter, the performance is possibly changed.

The self-priming ability decreases, or failure occurs. By this, stop to use the inverter.

10. Installing & piping

The correct installation leads to the appropriate performance. The necessary requirements of a self-priming pump are to discharge the air enters during self-priming and the priming liquid for the next operation remains. Install the pump in accordance with the following instruction for smooth self-priming operation.

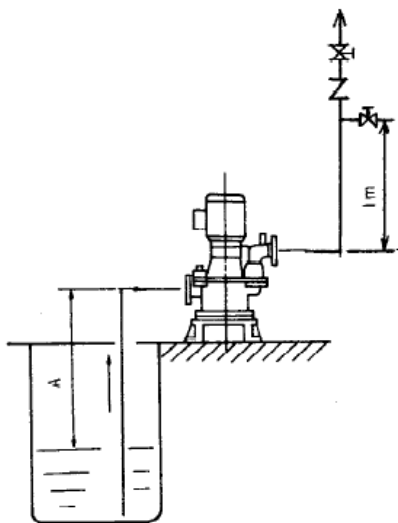

1. Provide the check valve at the discharge piping.
2. Be a vertical pipe of more than 1 meter at the discharge outlet and install the air release pipe with a valve.
3. Limit of suction height (Normal temperature / clear water)

Model	A (in terms of water)
YD-250*NSF(1)3	2.5m or less
	* LR: 2.0m or less
YD-400*NSF3	3.0m or less
YD-500*NSF3	3.5m or less
YD-800*SF3	
YD-100**SF3	

- (1) The limit of suction height “self-priming capacity” assumes that the suction pipe is provided vertically to the surface of water (clear water, 20°C). The actual self-priming capacity is affected by the type, temperature, viscosity, liquid specific gravity, shape and diameter of the suction pipe, the number of valves, the mixed air from the flange and valves, and other factors. It is recommended to use the pump with enough allowance in consideration with these conditions.
- (2) Provide the piping with 2 or more bends and expansion joints for heat release not to deform or damage the pump by thermal pipe expansion.
- (3) Do not use a foot valve at the suction pipe. (It is available for NSF-LR)

11. Troubleshooting

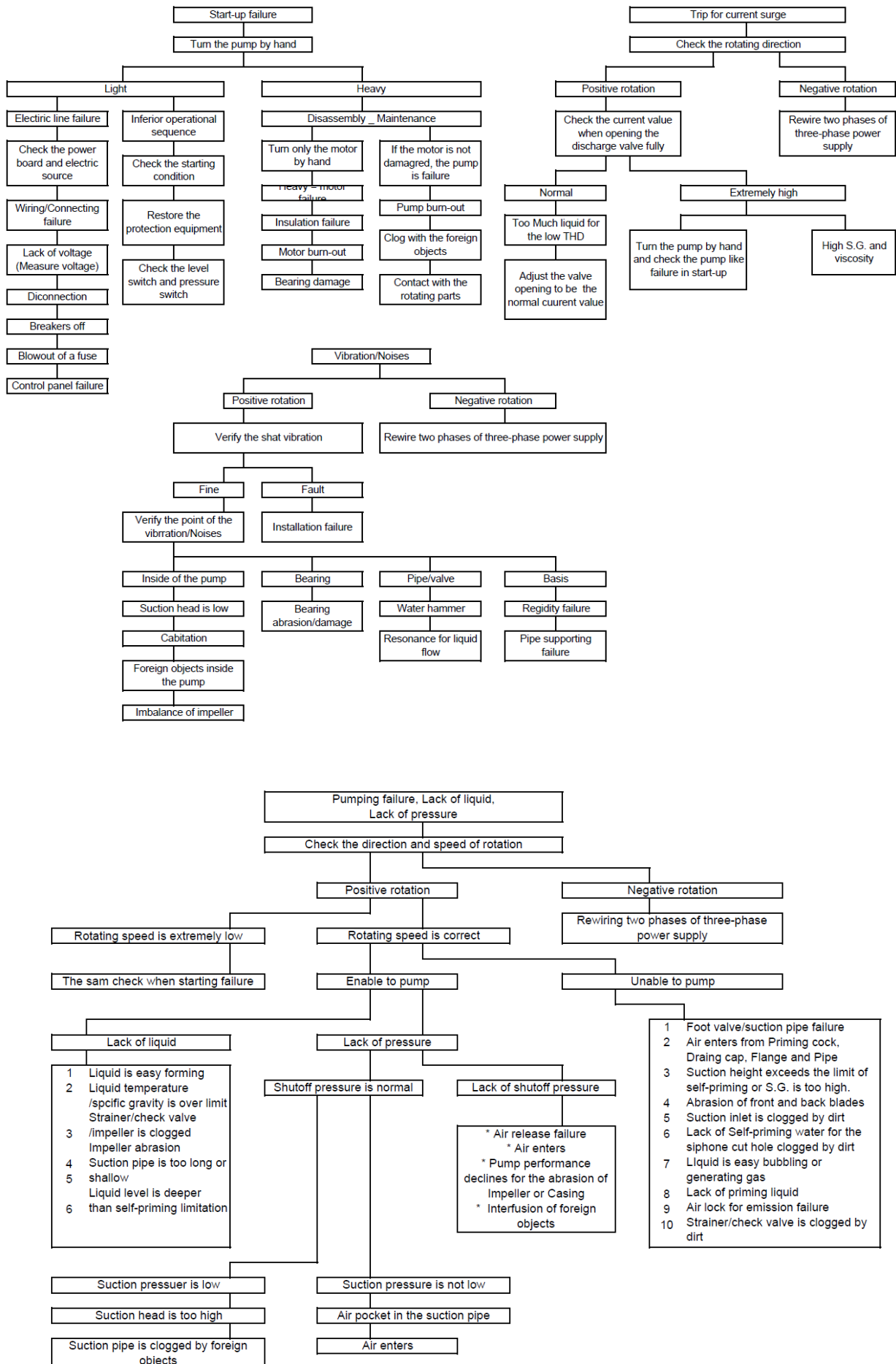

**WORLD CHEMICAL USA (“WCUSA”)
STANDARD ONE-YEAR LIMITED WARRANTY
FOR SALES MADE ONLY IN THE UNITED STATES, CANADA**

**This limited warranty completely replaces the warranty issued by World Chemical Co., Ltd.
relating to the below described Pumps.**

WCUSA warrants its Magnetic Drive Pumps, Self-Priming Pumps, Oil Skimmer Systems, Vertical Pumps and Submersible Pumps (“Pumps”) against defects in materials and workmanship for one year from the date of WCUSA’s invoice to you for the affected Pump. This warranty requires you to return the Pump to WCUSA.

If there is a manufacturing defect, WCUSA will replace or repair the Pump with new or rebuilt parts at no charge to you. Please return the Pump to: World Chemical USA, 30 Hughes, Ste 203, Irvine, CA 92618.

When returning the Pump, include your name, address, daytime telephone number, and a description of the problem. No warranty work can be performed without this information.

Properly pack the Pump (preferably in the original carton) to prevent damage to the Pump in transit.

The repaired or replaced Pump will be warranted for a period equal to the remainder of the original one-year warranty.

All replaced Pumps, parts and components, shall become the property of WCUSA

This Limited Warranty does not cover: (a) defects or damage resulting from accident, misuse, abnormal use, abnormal conditions, improper storage, exposure to dirt, neglect, or unusual physical, electrical or electromechanical stress; (b) scratches, dents and cosmetic damage, unless caused by WCUSA; (c) Pump that has the serial number removed, defaced, damaged, altered or made illegible; (d) ordinary wear and tear; (e) defects or damage resulting from the use of Pump in conjunction or connection with other equipment not furnished or approved by WCUSA; (f) defects or damage resulting from improper testing, operation, maintenance, installation, service, caused by the use of unauthorized parts of service; (g) defects or damage resulting from external causes such as collision with an object, fire, flooding, dirt, windstorm, lightning, earthquake, exposure to weather conditions, or improper use of any electrical source; (h) irregularities or breakdowns due to chemical or hydrodynamic corrosion by liquid. We do not warrant the chemical resistance of the Pump to any chemical or to corrosion.

You will be responsible for paying for your own shipping costs for delivering the Pump to us. If we determine the Pump is covered by this warranty, we will return the new or repaired Pump to you at our expense. If we determine that the Pump is not covered by this warranty, we will return it at

your expense.

WCUSA does not warrant accessory components, including, but not limited to, Impeller (including mouth ring and bushing), Rear Casing set (include shaft), O-Ring for Casing and other consumable parts.

REPLACEMENT OR REFUND OF THIS PUMP AS PROVIDED UNDER THIS LIMITED WARRANTY IS BE YOUR EXCLUSIVE REMEDY.

WE ARE NOT RESPONSIBLE OR LIABLE FOR ANY LOSS, INCONVENIENCE OR DAMAGE, WHETHER SPECIAL, DIRECT, INCIDENTAL, CONSEQUENTIAL, OR OTHERWISE, AND WHETHER KNOWN OR SHOULD HAVE BEEN KNOWN TO US, INCLUDING LOST PROFITS, GOODWILL, DAMAGE TO OR REPLACEMENT OF OTHER PUMPS AND PROPERTY AND PERSONAL INJURY RESULTING FROM ANY BREACH OF WARRANTY, THE INABILITY TO USE THE PUMP OR UNDER ANY LEGAL THEORY IN CONTRACT OR TORT. THESE WARRANTIES AND REMEDIES ARE YOUR SOLE AND EXCLUSIVE WARRANTIES AND REMEDIES IN CONNECTION WITH THE SALE AND USE OF THE PUMP. NO OTHER WARRANTIES, ORAL OR WRITTEN, EXPRESS OR IMPLIED, ARE GIVEN. OUR LIABILITY IS LIMITED TO THE ACTUAL PURCHASE PRICE YOU PAID TO THE RETAIL SELLER OF THE DEFECTIVE PUMP. EXCEPT TO THE EXTENT PROHIBITED BY LAW, ANY IMPLIED WARRANTIES OR CONDITIONS OF MERCHANTABILITY AND FITNESS FOR A PARTICULAR PURPOSE ARE LIMITED IN DURATION TO THE DURATION OF THIS LIMITED WARRANTY.

Some states do not allow the exclusion or limitation of implied warranties or liability for incidental or consequential damages, or do not allow a limitation on how long an implied warranty lasts, so the above limitations or exclusions may not apply to you. You are advised to contact applicable state laws for a full determination of your rights. This warranty gives you specific legal rights, and you may have other rights which vary from state to state.

No dealer, agent or employee is authorized to make any modification, extension, change or amendment to this warranty. This warranty may not be assigned without the prior expenses written approval of WCUSA.

Repair

Notice: When repairing, consult your supplier. Wash the wet parts kit for the returned pump adequately and pack it.

If any irregularity is detected during operation, stop the pump and check it. Refer to the section on “Troubleshooting”.

1. To request a repair service, ask your supplier or us.
2. Before requesting a repair service, read this instruction manual carefully and check it, again.
3. When requesting a repair service, provide the following information:
 - Pump model and serial number
 - The period of use and the condition
 - The failure parts and the condition
 - Type of liquid (name, specific gravity, temperature, any slurry or not)

Clean the inside of the pump adequately when returning it, because if the residual liquid leaks out during shipment, it creates a hazardous condition.

Use names in the parts table (P6, 7) to order for replacement or spare parts. Nevertheless, also provide the part number and the material just in case.

Model:	
Purchase date:	S/No.
Start date:	Supplier:



WORLD CHEMICAL CO., LTD. / Japan

Head Office / Overseas department

3F., ANTEX24, 1-1-14, Taito. Taito-ku, Tokyo, 110-0016 Japan

TEL: 03-5818-5130 FAX: 03-5818-5131 (Head office)

TEL: 03-5818-5131 FAX: 03-5818-5131 (Overseas department)

Osaka Office

7F., KUJO Bldg., 1-27-6, Kujo, Nishi-ku, Osaka-shi, Osaka, 550-0027 Japan

TEL: 06-6584-3185 FAX: 06-6584-3160

Nagoya Office

1F., EIKEI Bldg., 1-307, Yashirogaoka, Meito-ku, Nagoya-shi, Aichi, 465-0051 Japan

TEL 052-701-1227 FAX 052-701-1250

Tsukuba Factory

6127-5, Onogo-machi, Joso-shi, Ibaraki, 300-2521 Japan

TEL 0297-24-1071 FAX 0297-24-1075

WORCHEMI TAIWAN CO., LTD. / Taichung, Taiwan

No.915, Zhongshan Rd., Shengang Dist., Taichung City 42955, TAIWAN

TEL 886-4-2562-8358 FAX 886-4-2562-8351

WORLD CHEMICAL USA, INC. / California, U.S.A.

30 Hughes, Suite 203, Irvine, CA 92618, U.S.A.

TEL 1-949-462-0900 FAX 1-949-462-0999

SUZHOU WORLD TECHNOLOGY CO., LTD. / Jiangsu, China

402, Fu Yuan Road, Xiang Cheng Economic District, Suzhou, Jiangsu Province, China

TEL 86-0512-6579-8212 FAX 86-0512-6579-8215