

# Self-Priming Magnetic Pump - Polypro & ETFE YD-GV/GVF SERIES

For a wide range of industrial processing and transfer of acids, caustics, corrosives and wastewater to 100+ GPM - Sp. Gr. to 2.0

For transferring liquid where space is limited

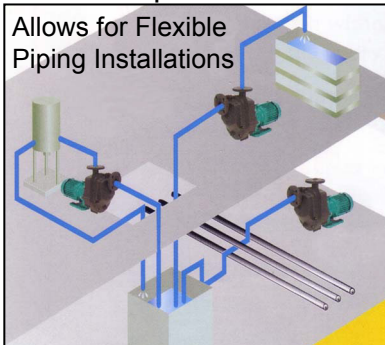

For transferring to or from a clean area to isolate the pump

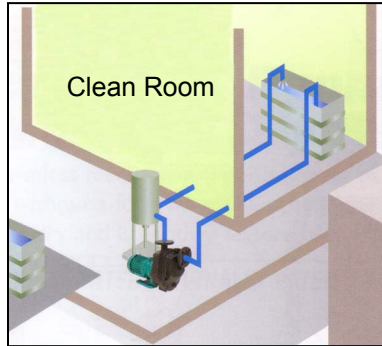

For transferring from a top outlet from a truck or rail tank

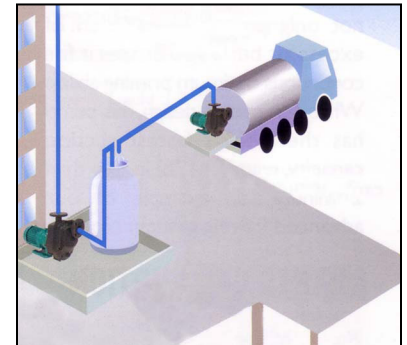

For transferring plating & etching liquid

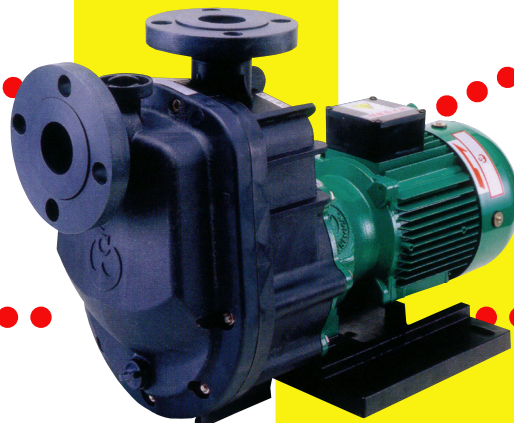
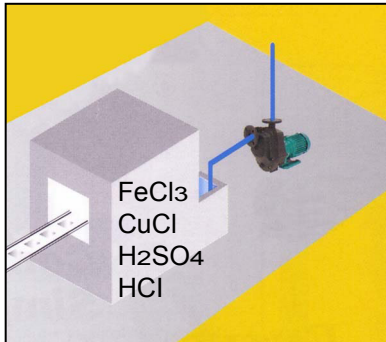

For transferring liquid from a drum

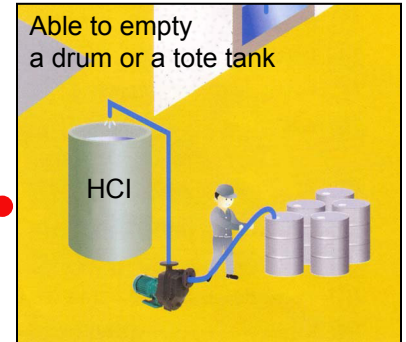

## FEATURES

- INTERNATIONALLY PATENTED:**  
Unique valveless mechanism & heat resistant bushing
- Fast suction lift - 17 feet (water) in less than 2 minutes
- Pumps air entrained liquids and resistant to dry running
- Loose ring flange for easy setup
- Reinforced ribbed casing for extra strength



[www.worldchemicalusa.com](http://www.worldchemicalusa.com)  
888-860-3364