

SUBMERSIBLE MAGNET DRIVE PUMP

SUBMERSE

YD-25A6GWN1

INSTRUCTION MANUAL
VERSION: 20240517

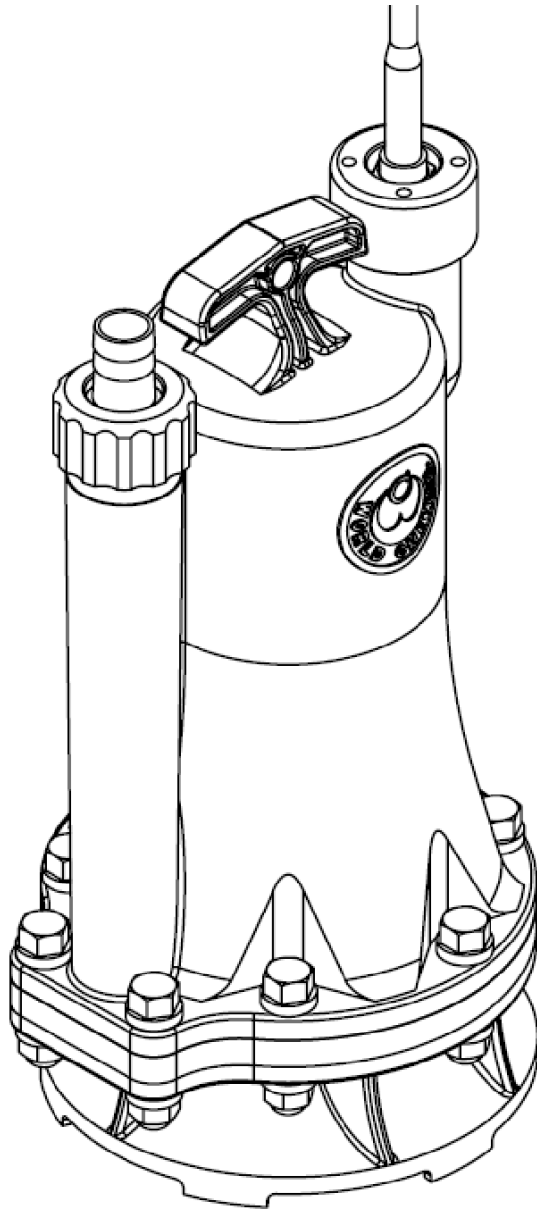

 **World Chemical Co., Ltd.**

Preface

Thank you for purchasing World Chemical's SUBMERSE submersible magnet drive pump. To effectively use SUBMERSE for an extended period, operating it correctly and maintaining it as described in the instruction manual is necessary. Before use, please read and understand the safety precautions outlined in this manual."

Meanwhile, we are not responsible for any accidents resulting from the use of the pump in a manner not indicated in this manual. If additional safety measures are required, please contact your supplier or us. The specifications of the pump and the information in this manual are subject to change without prior notice for improvements or design modifications."

Table of contents

1. Safety precaution.....	2
2. Model description • Specification/ Performance.....	7
3. Outline dimension / Parts.....	8
4. Installation.....	9
5. Connection of the power and motor.....	10
6. Check.....	10
7. Operation.....	12
8. Disassembly / Assembly.....	13
9. Troubleshooting.....	14
10. Warranty / Repair.....	15

1. Safety precaution

The following procedures are intended to protect you from personal injury and/or property damage.

- The following symbols classify the degree of danger and explain the damages that could occur when its contents are ignored or the pump is used improperly.
- Safety rules to be observed are classified and explained under the following symbols. (The following are examples of picture displays)



Warning

- (1) Dangerous liquid and surrounding

When using pumps which transfers dangerous liquid, make sure to perform the daily inspection not to leak leakage while observing the facility standards. The pump operation under an abnormal condition like liquid leakage causes a tragedy like person injury, explosion or fire. Follow the instructions of your supplier or the liquid manufacture about handling the liquid.

Never use the pump for flammable gas or liquid, also do not put flammable gas and liquid. (The explosion-proof motor is not adopted.)

When handling chemical liquid, wear protective glasses, gloves and protector like rubber boots. If contacting chemical liquid, immediately rinse with a large of clear water and submit medical treatment. If chemical liquid gets into eyes, immediately rinse the eyes with a large of clear water and submit medical treatment.



- (2) Prohibition of the use of damaged or modified pumps

Using damaged or modified pumps may cause personal injury, electrical shock or the pump damage. It is out of our warranty, so never use them.



(3) Caution in transporting and lifting pumps

Make sure to use the hoist bolt when lifting pumps with it. If pumps do not own the hoist bolt, lift them by a belt sling with care of the weight balance. The qualified person should perform this work with a sling strong enough. Carry pumps by hands may cause an accident, so stop it as possible.



(4) Prohibition on the operation when the power is on

Do not inspect or disassemble pumps or motors when applying power. It causes to get caught in the rotor or personal injury like electric shock. Take multiple safety measures like a handy switch of the pump as well as the main or operation switch.



(5) Connection with an earth wire

The operation of pumps without connecting an earth wire may cause electric shock. Make sure to connect it by a qualified person according to the electric equipment technical standards and interior wiring regulations.



(6) Protection of power supply codes

Stretching, pinching or damaging power or motor codes causes fire or electric shock by the damaged cable.



(7) Ground-Fault interrupter (GFI)

The operation of pumps without a ground fault interrupter may cause electric shock. Apply circuit breakers or over-current protective devices to prevent electric accidents or the motor damaged.



(8) Caution in removing pumps

When removing pumps from plumbing, make sure to close valves not to leak liquid. As the direct contacting with liquid may be harmful, always wear protective gears when operating.













(9) Maintenance

At the time of maintenance, inspection or repair, turn off the breaker for the primary side power and put "Working" sign not to happen personal injury by accidental power on. Especially, when multiple people work, speak each other not to return the breaker by accident.

Do not touch electrical equipment, wiring and switch by wet hands to prevent electrical shock. It causes personal injury, equipment failure, damage or trouble.

Caution

-  (1) Prohibition on the authorized use
Do not use pumps with the specification except for the indication on the nameplate. Install pumps after checking especially the motor specification (phase, voltage and frequency). Wrong use may cause person injury or the pump or peripheral equipment damaged.
-  (2) Restriction on handlers
Carry, install, wire, operation and maintain pumps by experts who have full knowledge of pumps.
-  (3) Caution when unpacked
Checking the upside down, unpack. When wooden crates are unpacked, be careful not to get injured by nails and wood.
-  (4) Repair and return
When repairing damaged pumps, contact your supplier or us. If the ump is returned by courier, clean the inside and outside of the pump with water, check no liquid adhered and pack it with a plastic bag.
-  (5) Resin parts
Pumps consist of resin parts. Pumps are damaged by strong impact, causing personal injury. Do not hit and climb on it. Besides, attach piping supports to prevent to apply a load directly. This is a plastic product, so unlike metal, the pressure capacity is depending on the temperature. If it is used for high temperature liquid, pay attention to the allowable pressure.
Component parts: Carbon fiber reinforced polypropylene / Alumina ceramics / CFR-PTFE
O-ring: FPM (fluorine-rubber)

Use for liquid which can be used for the material as above.
Chemical resistance is not assured, because it is affected by the liquid kind, concentration, temperature and interaction of multiple liquid, stress and time to the material and other variety of conditions. Therefore, perform a chemical resistant test against each material under the conditions for use before as possible.
Age deterioration by circumstances of the installation place surely is occurred. It is recommended to have a daily inspection for safety use for a long time and handle it as soon as possible (including parts replacement).
-  (6) Pump start-up
Never run pumps dry. The bearing of the impeller and shaft are burn out and molded thermoplastic parts are dissolved, causing liquid leakage and the pump damaged.
-  (7) Pump operation
Do not operate pumps instantly like repeat to start/stop for a few seconds. It is not designed in that way. It is for the continuous operation.
The change of the load in the pump causes liquid leakage from parts connections or the material fatigue failure. Also, do not operate pumps continuously while the discharge valve is opened/closed for a second.
-  (8) Disposal of pumps
Disposing pumps, handle them as the industrial waste according to the appropriate law after cleaning adhered liquid.
-  (9) Leak protection
In case, make sure to take appropriate preventative measures in consideration of liquid leakage from pumps and piping damaged.
- 

(10) Liqui for use

When using pumps for the hazardous tank like cyanogen tank, provide adequate protection for unexpected liquid leakage. Take safety measures. Install equipment to handle sudden accidents. Attach liquid-level controllers and Install equipment that it stops the pump as soon as alarm sounds and fully closes valves when the liquid is decreased.

The impeller is contained magnets. If the pump is used for liquid with iron powder or slurry, the parts are wormed or damaged.

Limit of liquid for use

Temperature: 40 degree (104F) or less
Viscosity: 30mPa·s or less (20 degrees, S.G. 1.0)



(11)Disassembling pumps

Do not disassemble the motor including the cable.

Using the pump which is disassembled or assembled by your self may be out of our warranty. Do not disassemble the pump as possible.

When requesting overhaul, contact your supplier or us.

2. Model description · Specification/ Performance

YD - 25 A6 GWN1 – CP – R D 5 2

(1) (2) (3) (4) (5) (6) (7) (8)

- (1) Discharge outlet 25: 25A
- (2) Motor output / voltage A6: Single phase / 115V / 260W
- (3) Pump model GWN1: Submersible pump
- (4) Main material CP: Carbon fiber reinforced polypropylene (CFR PP)
- (5) Bearing material R: Carbon fiber reinforced PTFE (CFR PTFE)
- (6) O-ring material D: FPM (Fluorine-rubber)
- (7) Frequency 5: 50Hz 6: 60Hz
- (8) Limit of liquid specific gravity 2: S.G.1.2

[Standard performance]

Model	Frequency Hz	S.G.	Standard performance		Motor			Weight	Liquid temperature (Max)
			T.H.D.	Capacity	Output	Voltage/PH	Ins.		
YD-25A6GWN1-CP-RD5 2	50	1.2	6m(19ft)	60L/min (15gpm)	0.26k W (1/3HP)	115V Single	E	14kg (30lbs)	0~40°C (32-104F)
YD-25A6GWN1-CP-RD6 2	60		6.5m(21ft)						

[Caution]

- The above standard performance is under the clear water (S.G.1.0) and 20 degrees.(68F)
- The minimum flow rate during operation: 5L/min(1.3gpm)
- The dimension of the hose: Inner diameter 25mm x Outer diameter 33mm (1" x 1.3")
- The minimum liquid level at continuous operation: 400mm (15")
- The minimum operational liquid level: 100mm (4")

3. Outline dimension / Parts

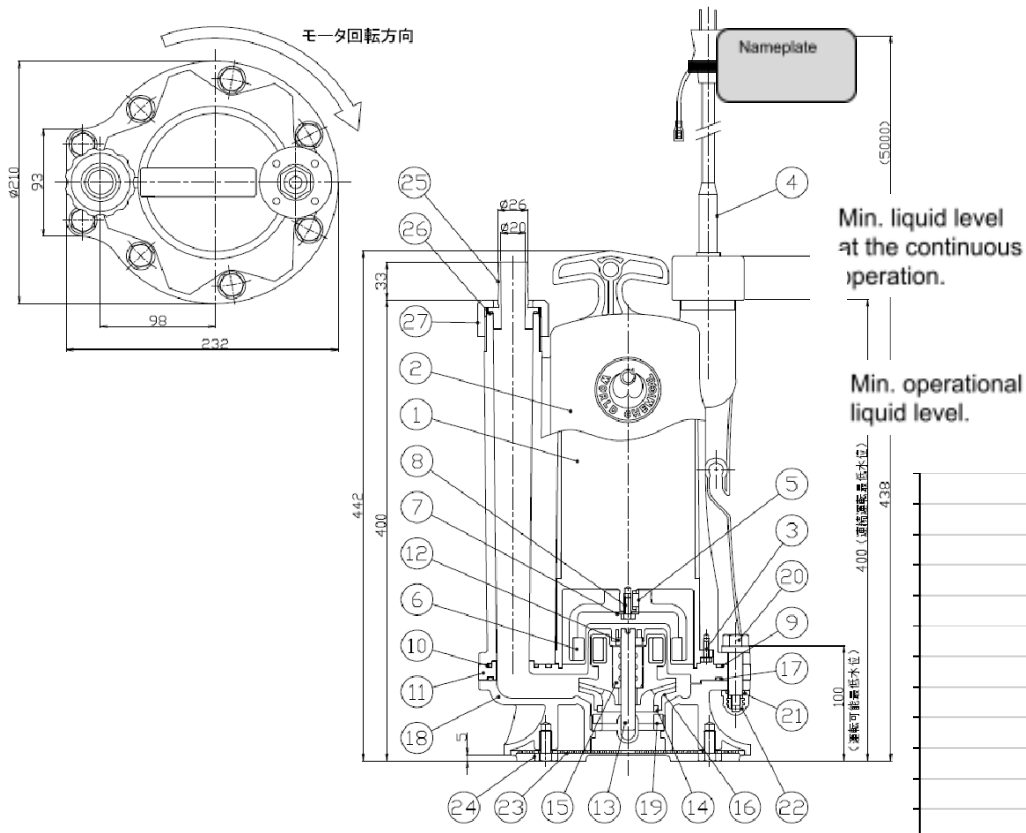

No.				
1	M			
2	M			
3	H			
4	C			
5	K			
6	O			
7	F			
8	H			
9	C			
10	O			
11	R			
12	Rear thrust ring	1	Alumina ceramic	
13	Shaft	1	Alumina ceramic	
14	Mouth ring	1	CFR PTFE	
15	Bearing	1	CFR PTFE	
16	Impeller	1	CFR PP	
17	O-ring for casing	1	FPM	
18	Casing	1	CFR PP	
19	Liner ring	1	Alumina ceramic	
20	Bet bolt 37	8	CFR PP	
21	O-ring for set bolt	8	FPM	P12
22	Set bolt nut	8	CFR PP	
23	Strainer	1	CFR PP	
24	Hex. Bolt for strainer	4	PVC	M10 x 20
25	Hose joint	1	CFR PP	
26	O-ring for hose joint	1	FPM	P34
27	Hose joint nut	1	CFR PP	

4. Installation

Warning

**⚠️ All Ground Fault Interrupter to prevent the electrical shock!
Connect an earth wire!**

- When installing a pump, use a rope to move it up and down. Do not use the power supply code to move the pump. It may cause electrical leakage.
- If proper fixation is provided, Hanging operation is possible.
- Install the pump at the site without slurry. If the suction inlet is clogged by slurry, it causes the pump damage.

- Check the liquid level is 100mm (4") and more when starting the pump. If not, it may cause dry running and the pump damaged.

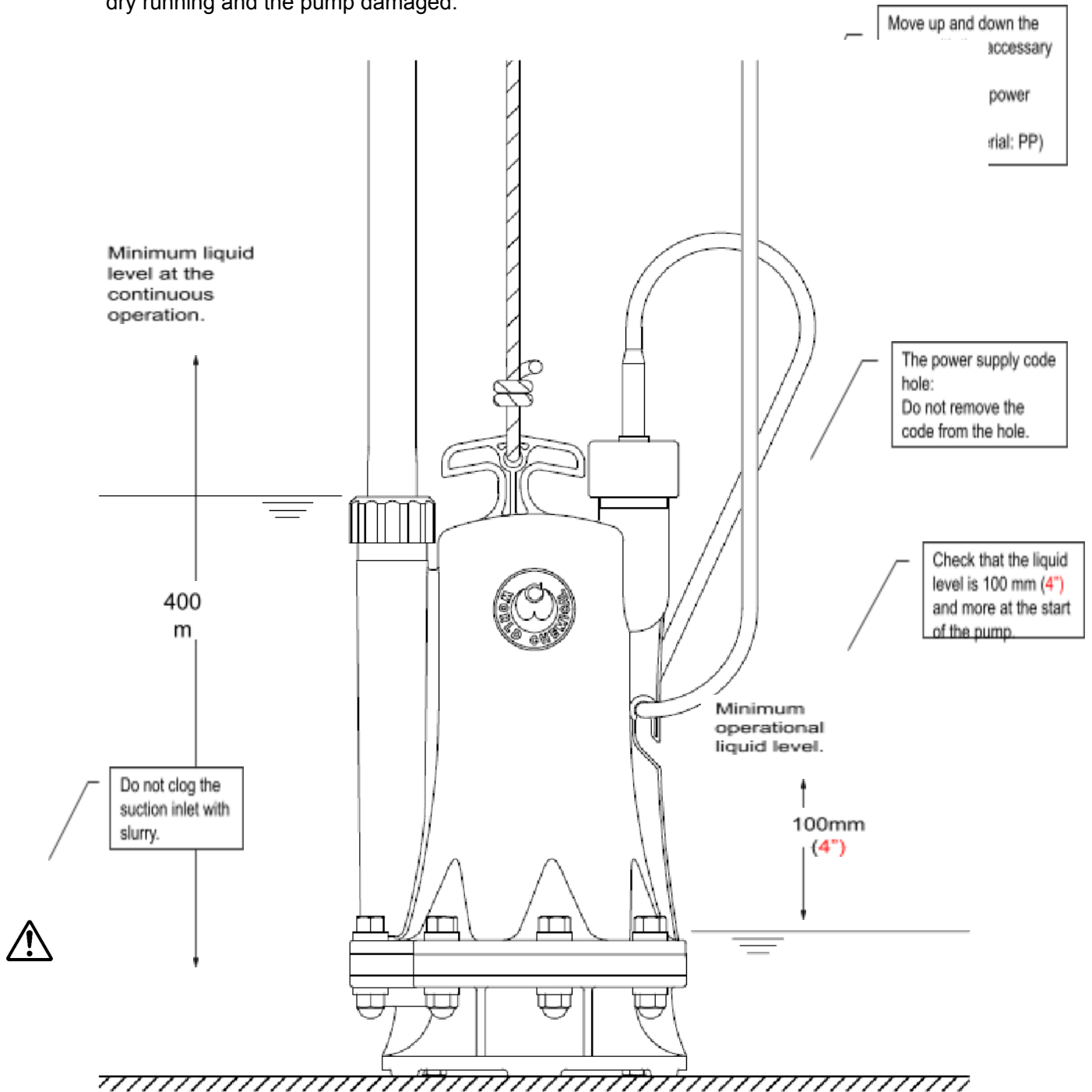

5. Connection of the power and motor

Warning

- **Install Ground Fault Interrupter to prevent electrical shock!**
- When maintaining, checking or repairing, turn off the wiring circuit breaker of the primary side and place a sign “Men working” not to turn on the switch by mistake. Especially, when multiple people work together, call out each other not to power on by mistake.
- **Make sure to connect the earth wire.**
Use the plug tab when connecting it.
- When installing the sensitive current variable type earth leakage breaker, follow the directions given by the licensed electrical engineer.
The up and down of the sensed current and the prevention of electrical shock/insulated resistance are conflicting.
- Do not touch the electrical equipment, wire and switch by wet hands to prevent the electrical shock.
- Check periodically whether the motor wiring terminal in the power board is burn or discolored. If the terminal is loosened, it may cause the burn out for heat or fire. Work it by the licensed electrical engineer.

6. Check

1. Daily inspection
 - Before operation, make sure to check pumps.

Content to be inspected		Repetition	
		Daily	Monthly
1. Before Operation	1-1 Open/close of the handle for the discharge valve	◎	
	1-2 Piping deformation by liquid temperature	◎	
	1-3 Liquid leakage from the outside of piping	◎	
	1-4 Loosen bolts		◎
	1-5 Liquid leakage from the outside of cable	◎	
	1-6 Insulation		◎
	1-7 Cleaning	◎	
2. During Operation	2-1 Current value	◎	
	2-2 Discharge pressure	◎	

2. Periodically inspection
 - 1 Have an overhaul periodically for the smooth use.
 - 2 When the installation place is changed or the pump is moved, drain and wash thoroughly for safety. * Frequency: once a year or 1,000 hours / Keep the record.
3. Periodically check the consumable parts as follows and replace as necessary.
 - 1 Bearing (No.15) The inner diameter of the new one is $\phi 12.0$ mm.
 - ◎ Check no cracks or damage on the bearing.
 - ◎ Check that the rattle between the bearing and shaft is not increased. (The limit of the inner diameter $\phi 12.5$ mm)
 If the total wear volume is 0.5mm and more, replace the more worn parts.
 - 2 Shaft (No. 13) The outer diameter of the new one is $\phi 12.0$ mm.
 - ◎ Check not cracks or damage on the shaft.
 - ◎ Check that the rattle between the bearing and shaft is not increased. (The limit of the inner diameter $\phi 11.5$ mm)
 If the total wear volume is 0.5mm and more, replace the more worn parts.
 - 3 Mouth ring (No. 17)
 - ◎ If there are scratch and hitting marks on the month ring, replace it.
 - ◎ Check the wear volume as viewed from the side of the impeller. (The limit difference 0.5 mm)

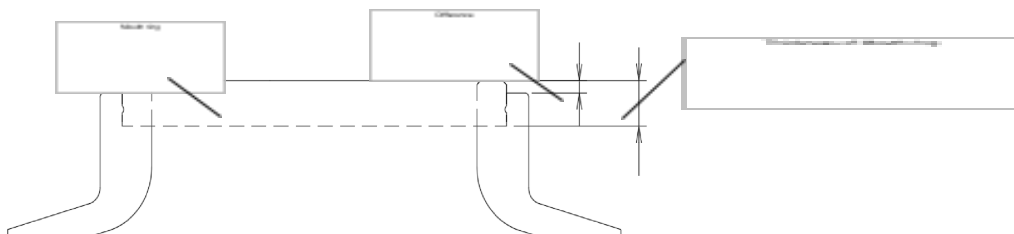



4 Liner ring (No. 19)

- ⊙ Check no cracks or damage.
- ⊙ Check the wear volume of the liner ring. (The limit difference 0.5 mm)

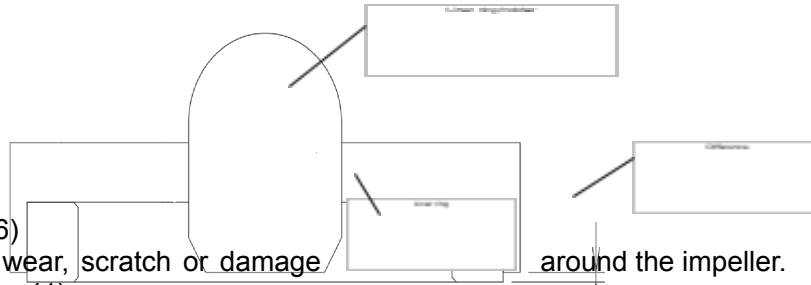

5 Impeller (No. 16)

- ⊙ Check no wear, scratch or damage around the impeller.

6 Rear casing (No. 11)

- ⊙ Check no wear, scratch or damage inside/outside of the rear casing.

7 Casing (No. 18)

- ⊙ Check no foreign objects inside of the front casing.

8 O-ring (No. 9, 10, 17, 21, 26)

- ⊙ Check that the rubber is hardened by degradation or

7. Operation



Caution

- After operation, check no liquid leakage, the noise of the pump and motor and the state of drain. If the abnormal state is found, stop the pump immediately and take measures.
- When blackout or the electric power failure, turn off the switch and start each pump one by one after recovery.
- The minimum liquid level during operation
 The minimum liquid level during operation
 Keep the liquid level which the whole of the pump is submerged in.
 (The minimum liquid level at continuous operation: 400mm and more from the mounting surface of the pump)
 If the pump is operated at continuous operation below the minimum liquid level, it is 5 minutes or less. Do not operate the pump at short intervals.
 - ※ According to the operation condition, the built-in thermal protector works and the pump stops. At such times, pause the operation and check whether there is abnormality. After securing the proper liquid level, start the pump.
 The operational minimum liquid level at the start of the pump is 100mm and more.
 - ※ Even if the liquid level is over the operational liquid level, air may enter the pump and the operation may be failure depending on the condition of the liquid surface.
 - ※ When operating the pump in the air, the rotation parts inside of the pump may be damaged.
- Measures against air lock
 If there are areas in the discharge pipe where liquid stands when stopping the pump, pumping failure may occur at the re-start of the operation by air lock. The same phenomenon easily happens after deadhead running. In this case, install the air release valve on the discharge pipe, or make sure to release the air and pour priming liquid in the pump casing before the operation.

When placing check valves on the suction pipe, install exhaust bypass pipes underneath. (If there is not air release pipe, it may cause air lock.)

8. Disassembly / Assembly

[Disassembly]

- [A] Remove eight bolts (20) which fix the motor cover (2) and the casing (18).
- [B] The parts below the rear casing (11) is separated from the motor cover (2).
- [C] Heave the rear casing (11) and remove the impeller (16).
 - ※ At this time, the motor becomes exposed and be careful not to wet the metal part by chemical liquid.
 - ※ Do not be adhered the dirt or foreign objects to the O-rings or seal parts.

[Assembly]

- [A] Check the motor dry, clean O-rings off and set them as the same way as disassembly.
- [B] Tighten the set bolts (20) alternately and diagonally with the torque 7.5N·m.

- **Never disassemble the motor.**

In our factory, the pressure resistant / leaked tests are conducted to check that no liquid enters in.

The use after customer disassembles and assembles the motor is not covered by warranty.

When overhauling a pump, contact your supplier or us.

- **Exploded view**

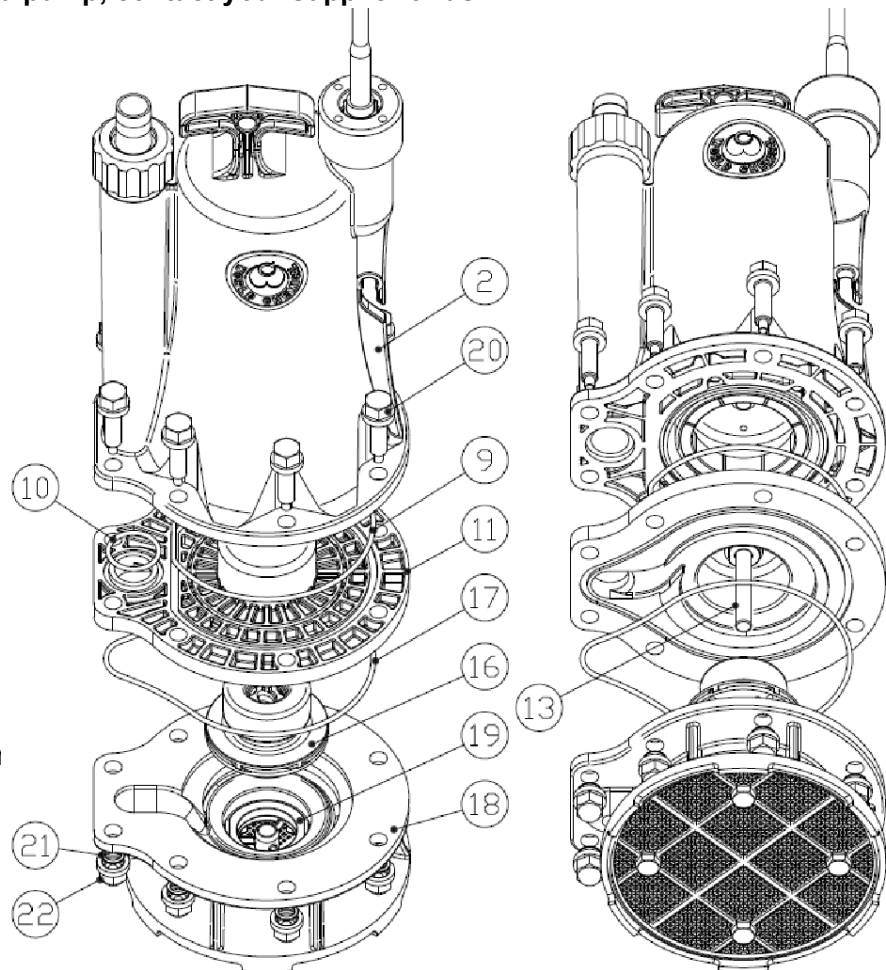

9. Troubleshooti

1. Unable to pump up and ii

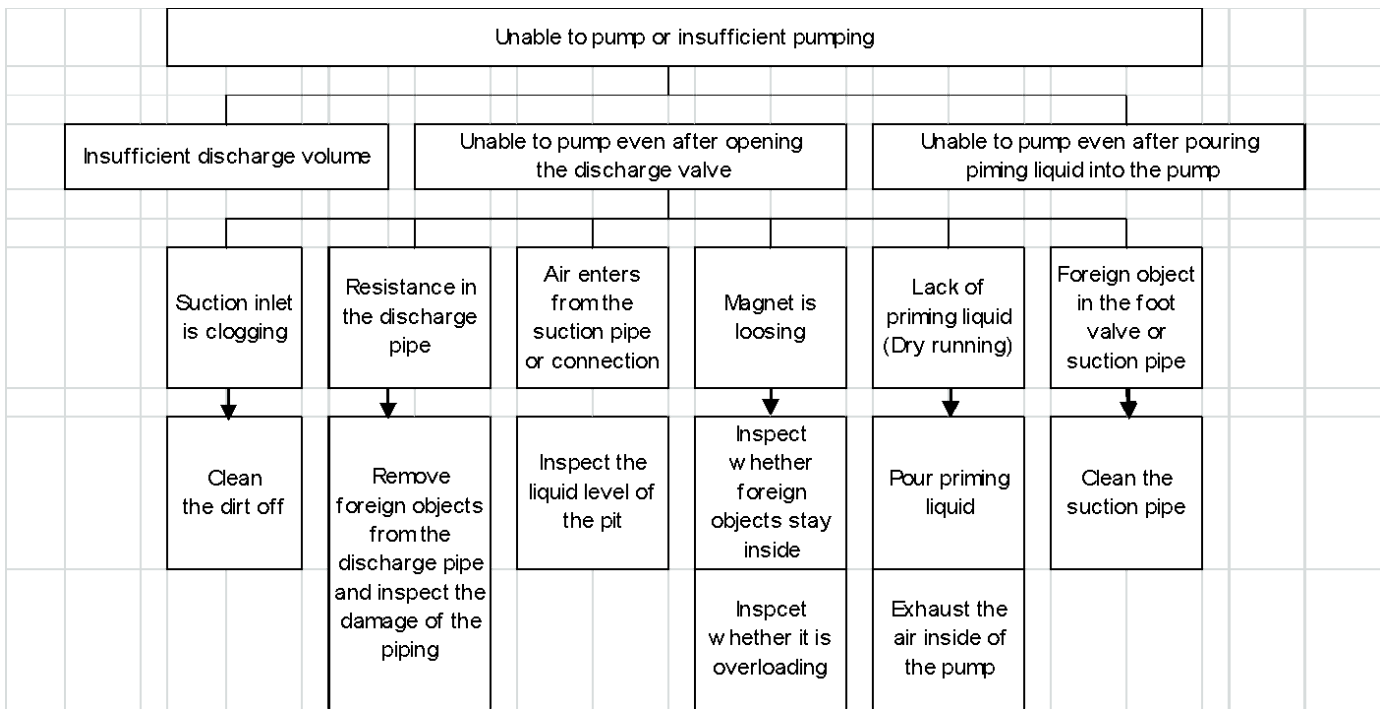

2. Pump vibrates

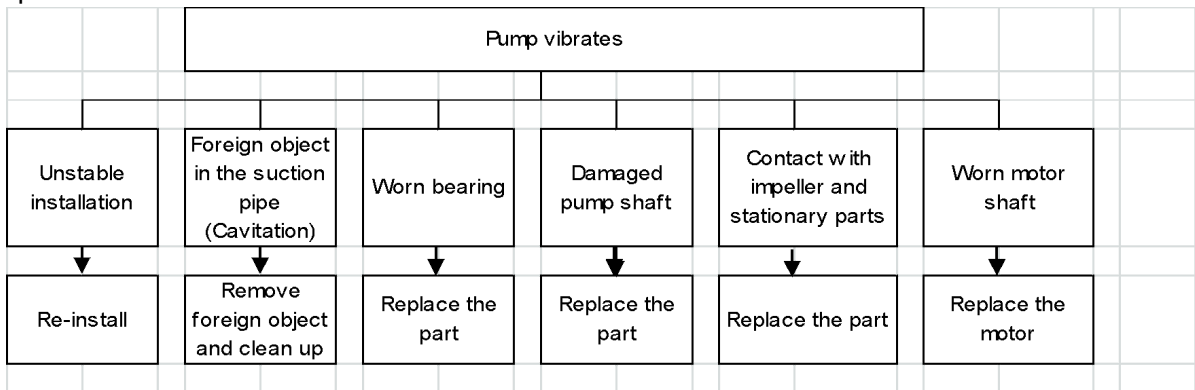

10. Warranty / Repair

STANDARD ONE-YEAR LIMITED WARRANTY FOR SALES MADE ONLY IN THE UNITED STATES, CANADA

This limited warranty completely replaces the warranty issued by World Chemical Co., Ltd. relating to the below described Pumps.

WCUSA warrants its Magnetic Drive Pumps, Self-Priming Pumps, Oil Skimmer Systems, Vertical Pumps and Submersible Pumps (“Pumps”) against defects in materials and workmanship for one year from the date of WCUSA’s invoice to you for the affected Pump. This warranty requires you to return the Pump to WCUSA.

If there is a manufacturing defect, WCUSA will replace or repair the Pump with new or rebuilt parts at no charge to you. Please return the Pump to: World Chemical USA, 25691 Atlantic Ocean Dr. Unit B-15 Lake Forest, CA 92630.

When returning the Pump, include your name, address, daytime telephone number, and a description of the problem. No warranty work can be performed without this information.

Properly pack the Pump (preferably in the original carton) to prevent damage to the Pump in transit.

The repaired or replaced Pump will be warranted for a period equal to the remainder of the original one-year warranty.

All replaced Pumps, parts and components, shall become the property of WCUSA

This Limited Warranty does not cover: (a) defects or damage resulting from accident, misuse, abnormal use, abnormal conditions, improper storage, exposure to dirt, neglect, or unusual physical, electrical or electromechanical stress; (b) scratches, dents and cosmetic damage, unless caused by WCUSA; (c) Pump that has the serial number removed, defaced, damaged, altered or made illegible; (d) ordinary wear and tear; (e) defects or damage resulting from the use of Pump in conjunction or connection with other equipment not furnished or approved by WCUSA; (f) defects or damage resulting from improper testing, operation, maintenance, installation, service, caused by the use of unauthorized parts of service; (g) defects or damage resulting from external causes such as collision with an object, fire, flooding, dirt, windstorm, lightning, earthquake, exposure to weather conditions, or improper use of any electrical source; (h) irregularities or breakdowns due to chemical or hydrodynamic corrosion by liquid. We do not warrant the chemical resistance of the Pump to any chemical or to corrosion.

You will be responsible for paying for your own shipping costs for delivering the Pump to us. If we determine the Pump is covered by this warranty, we will return the new or repaired Pump to you at our expense. If we determine that the Pump is not covered by this warranty, we will return it at your expense.

WCUSA does not warrant accessory components, including, but not limited to, Impeller (including mouth ring and bushing), Rear Casing set (include shaft), O-Ring for Casing and other consumable parts.

REPLACEMENT OR REFUND OF THIS PUMP AS PROVIDED UNDER THIS LIMITED

WARRANTY IS BE YOUR EXCLUSIVE REMEDY.

WE ARE NOT RESPONSIBLE OR LIABLE FOR ANY LOSS, INCONVENIENCE OR DAMAGE, WHETHER SPECIAL, DIRECT, INCIDENTAL, CONSEQUENTIAL, OR OTHERWISE, AND WHETHER KNOWN OR SHOULD HAVE BEEN KNOWN TO US, INCLUDING LOST PROFITS, GOODWILL, DAMAGE TO OR REPLACEMENT OF OTHER PUMPS AND PROPERTY AND PERSONAL INJURY RESULTING FROM ANY BREACH OF WARRANTY, THE INABILITY TO USE THE PUMP OR UNDER ANY LEGAL THEORY IN CONTRACT OR TORT. THESE WARRANTIES AND REMEDIES ARE YOUR SOLE AND EXCLUSIVE WARRANTIES AND REMEDIES IN CONNECTION WITH THE SALE AND USE OF THE PUMP. NO OTHER WARRANTIES, ORAL OR WRITTEN, EXPRESS OR IMPLIED, ARE GIVEN. OUR LIABILITY IS LIMITED TO THE ACTUAL PURCHASE PRICE YOU PAID TO THE RETAIL SELLER OF THE DEFECTIVE PUMP. EXCEPT TO THE EXTENT PROHIBITED BY LAW, ANY IMPLIED WARRANTIES OR CONDITIONS OF MERCHANTABILITY AND FITNESS FOR A PARTICULAR PURPOSE ARE LIMITED IN DURATION TO THE DURATION OF THIS LIMITED WARRANTY.

Some states do not allow the exclusion or limitation of implied warranties or liability for incidental or consequential damages, or do not allow a limitation on how long an implied warranty lasts, so the above limitations or exclusions may not apply to you. You are advised to contact applicable state laws for a full determination of your rights. This warranty gives you specific legal rights, and you may have other rights which vary from state to state.

No dealer, agent or employee is authorized to make any modification, extension, change or amendment to this warranty. This warranty may not be assigned without the prior expenses written approval of WCUSA.

Repair

Notice: When repairing, consult your supplier. Wash the wet parts kit for the returned pump adequately and pack it.

If any irregularity is detected during operation, stop the pump and check it. Refer to the section on “Troubleshooting”.

1. To request a repair service, ask your supplier or us.
2. Before requesting a repair service, read this instruction manual carefully and check it, again.
3. When requesting a repair service, provide the following information:
 - Pump model and serial number
 - The period of use and the condition
 - The failure parts and the condition
 - Type of liquid (name, specific gravity, temperature, any slurry or not)

Clean the inside of the pump adequately when returning it, because if the residual liquid leaks out during shipment, it creates a hazardous condition.

Use names in the parts table (P6) to order for replacement or spare parts. Nevertheless, also provide the part number and the material just in case.

Model:	
Purchase date:	Serial No.
Date to start:	Supplier:



WORLD CHEMICAL CO., LTD. / Japan

Head Office / Overseas department

3F., 1-1-14, Taito. Taito-ku, Tokyo, 110-0016 Japan

TEL 81-3-5818-5130 FAX 81-3-5818-5131 (Head office)

TEL 81-3-5818-5131 FAX 81-3-5818-5131(Overseas epartment)

Osaka Office

3F., 1-19-25, Edobori, Nishi-ku, Osaka-shi, Osaka, 550-0002 Japan

TEL 81-6-6467-8565 FAX 81-6-6467-8566

Nagoya Office

9F., 1-11-20, Nishiki, Naka-ku, Nagoya-shi, Aichi, 460-0003 Japan

TEL 81-52-253-8426 FAX 81-52-253-8436

Fukuoka Office

5F., 2-17-19, Hakataekimae, Hakata-ku, Fukuoka-shi, Fukuoka,
812-0011 Japan

TEL 81-92-710-6001 FAX 81-92-710-6125

Tsukuba Factory

6127-5, Onogo-machi, Joso-shi, Ibaraki, 300-2521 Japan

TEL 81-297-24-1071 FAX 81-297-24-1075

WORCHEMI TAIWAN CO., LTD. / Taichung, Taiwan

No.915, Zhongshan Rd., Shengang Dist., Taichung City 42955, TAIWAN

TEL 886-4-2562-8358 FAX 886-4-2562-8351

WORLD CHEMICAL USA, INC. / California, U.S.A.

25691 Atlantic Ocean Dr. Unit B-15 Lake Forest, CA 92630, U.S.A.

TEL 1-949-462-0900 FAX 1-888-860-3364

SUZHOU WORLD TECHNOLOGY CO., LTD. / Jiangsu, China

402, Fu Yuan Road, Xiang Cheng Economic District, Suzhou, Jiangsu Province, China

TEL 86-0512-6579-8212 FAX 86-0512-6579-8215

WARNING

Do NOT LIFT the pump **with a cable** to avoid malfunctions or electrical issues.

**DO NOT USE THIS PUMP WITH:
SLURRY, SLUDGE OR OTHER SMALL
PARTICULATES THAT COULD CAUSE
THE PUMP TO BECOME INOPERABLE.**

**AFTER EACH USE OF PUMP, IT MUST BE TAKEN OUT FROM TANK
AND RINSE WELL WITH WATER TO KEEP IT IN OPTIMUM QUALITY.**